

---

**User's  
Manual**

**Model SCMS  
(Style E)  
Programmable  
Computing Station**

**YEW SERIES 80**

IM 1B4D6-01E

---

# Notices

## ■ Regarding This User's Manual

- (1) This manual should be passed on to the end user. Keep at least one extra copy of the manual in a safe place.
- (2) Read this manual carefully and fully understand how to operate this product before you start operation.
- (3) This manual is intended to describe the functions of this product. Yokogawa Electric Corporation (hereinafter simply referred to as Yokogawa) does not guarantee that the functions will suit a particular purpose of the user.
- (4) Under absolutely no circumstances may the contents of this manual in part or in whole be transcribed or copied without permission.
- (5) The contents of this manual are subject to change without prior notice.
- (6) Every effort has been made to ensure accuracy in the preparation of this manual. Should any error or omissions come to your attention however, please contact your nearest Yokogawa representative or our sales office.

## ■ Regarding Protection, Safety, and Prohibition against Unauthorized Modification

- (1) In order to protect the product and the system controlled by it against damage and ensure its safe use, make certain that all of the instructions and precautions relating to safety contained in this manual are strictly adhered to. Yokogawa does not guarantee safety if products are not handled according to these instructions.
- (2) Be sure to use the spare parts approved by Yokogawa when replacing parts or consumables.
- (3) Modification of the product is strictly prohibited.
- (4) Reverse engineering such as the disassembly or decompilation of software is strictly prohibited.
- (5) No portion of the software supplied by Yokogawa may be transferred, exchanged, leased or sublet for use by any third party without the prior permission of Yokogawa.

## ■ Force Majeure

- (1) Yokogawa does not make any warranties regarding the product except those mentioned in the WARRANTY that is provided separately.
- (2) Yokogawa assumes no liability to any party for any loss or damage, direct or indirect, caused by the user or any unpredictable defect of the product.



## CONTENTS

<i>Section</i>	<i>Title</i>	<i>Page</i>
<b>1.</b>	<b>HANDLING PRECAUTIONS.</b>	1-1
1-1.	Confirm Model and Suffix Codes.	1-1
1-2.	References.	1-1
<b>2.</b>	<b>GENERAL.</b>	2-1
2-1.	Standard Specifications.	2-1
2-2.	Model and Suffix Codes.	2-2
2-3.	Optional Specifications.	2-2
2-4.	Accessories.	2-2
<b>3.</b>	<b>INSTALLATION.</b>	3-1
3-1.	Wiring.	3-1
3-1-1.	Wiring Precautions.	3-2
<b>4.</b>	<b>PRINCIPLES OF OPERATION.</b>	4-1
4-1.	Circuit Descriptions.	4-1
4-1-1.	Analog Input Circuit	4-1
4-1-2.	Analog-to-Digital Converter Circuit	4-1
4-1-3.	Status Input Circuit	4-1
4-1-4.	Digital Computing Circuit	4-1
4-1-5.	Analog Output Circuit	4-1
4-1-6.	Status Output Circuit	4-1
4-2.	Principles of Computation.	4-1
4-2-1.	Principles of Computation.	4-1
4-2-2.	Input/Output Register Configuration.	4-2
<b>5.</b>	<b>OPERATION.</b>	5-1
5-1.	Front- and Side-Panel Features.	5-1
5-1-1.	Front-Panel Components.	5-1
5-1-2.	Side-Panel Components.	5-3
5-2.	Preparations for Operation.	5-6
5-2-1.	How to Draw out the Internal Assembly from the Housing.	5-6
5-2-2.	Checking Installed Parts.	5-6
5-2-3.	Preparations for Operation.	5-6
5-3.	Startup and Operation.	5-10
5-3-1.	Data Display	5-10
5-3-2.	Parameter Setting	5-10
5-4.	Actions to be Taken When FAIL and/or ALM Lamp Are Lit.	5-10
5-4-1.	For FAIL Lamp Lit.	5-10
5-4-2.	For ALM Lamp Lit.	5-11
5-4-3.	For ALM Lamp Flashing.	5-11
5-4-4.	CHK Display	5-11
5-5.	Connecting SPRG Programmer.	5-11
5-5-1.	Connecting SPRG Programmer.	5-11
5-5-2.	Disconnecting SPRG Programmer.	5-12
<b>6.</b>	<b>MAINTENANCE.</b>	6-1
6-1.	Nameplate for Tag Label Replacement	6-1
6-2.	Fuse Replacement.	6-1
6-3.	Data Memory Backup Battery Replacement	6-2
6-4.	User ROM Replacement.	6-4

<u>Section</u>	<u>Title</u>	<u>Page</u>
<b>7.</b>	<b>TROUBLESHOOTING.</b>	7-1
7-1.	Troubleshooting Flowcharts.	7-1
7-2.	Disassembling and Reassembling Procedures.	7-7
7-2-1.	Removing Cover.	7-7
7-2-2.	Removing Display Assembly.	7-7
7-2-3.	Removing Power Supply Unit.	7-7
7-2-4.	Disassembling Control Assembly.	7-7
7-2-5.	Reassembling.	7-7
7-2-6.	Checks in Re-supplying Power.	7-7
●	<b>Data Label.</b>	Appendix I
●	<b>Customer Maintenance Parts List</b>	CMPL 1B4D6-03E
●	<b>POWER SUPPLY TERMINALS for PANEL-MOUNTED INSTRUMENTS (for /HTB)</b>	<b>IM 1B4F1-11E</b>

### 1. HANDLING PRECAUTIONS.

This instrument is thoroughly factory-tested before shipment. When the instrument is received, however, check visually for any external damage caused during transit. Insure that it is complete with all standard accessories.

Read this chapter carefully before operating the SCMS Programmable Computing Station. For items not covered in this chapter refer to the appropriate sections in the manual.

#### 1-1. Confirm Model and Suffix Codes.

Model and suffix codes are indicated in the nameplate on the side of the instrument. Check them against the model and suffix codes given in Section 2-2 to make sure that the instrument meets your specifications.

If you have any questions about this instrument, please contact either your nearest YOKOGAWA Sales & Service Office or YOKOGAWA Electric Corporation, Tokyo Japan.

#### 1-2. References.

This instruction manual provides information about the handling of the SCMS Programmable Computing Station, its operational sequences, and simplified maintenance workflows.

To run the SCMS to fully support your applications, certain preparatory steps are required, including the processes of generating a program in instrumentation flow sheet forms and loading the resultant program in read-only memory (ROM). (See Figure 1-2-1.)

Information on these operations is available in specific manuals.

**Step 1: Information and material related to program generation.**

- ① Functions and Applications of YEW SERIES 80 Programmable Instruments – Technical Information TI 1B4C2-02E.
- ② SCMS Worksheet Form WS 1B4C2-11E.
- ③ SCMS Data Sheet Form WS 1B4C2-13E, 14E.
- ④ SCMS Program Sheet Form WS 1B4C2-15E.

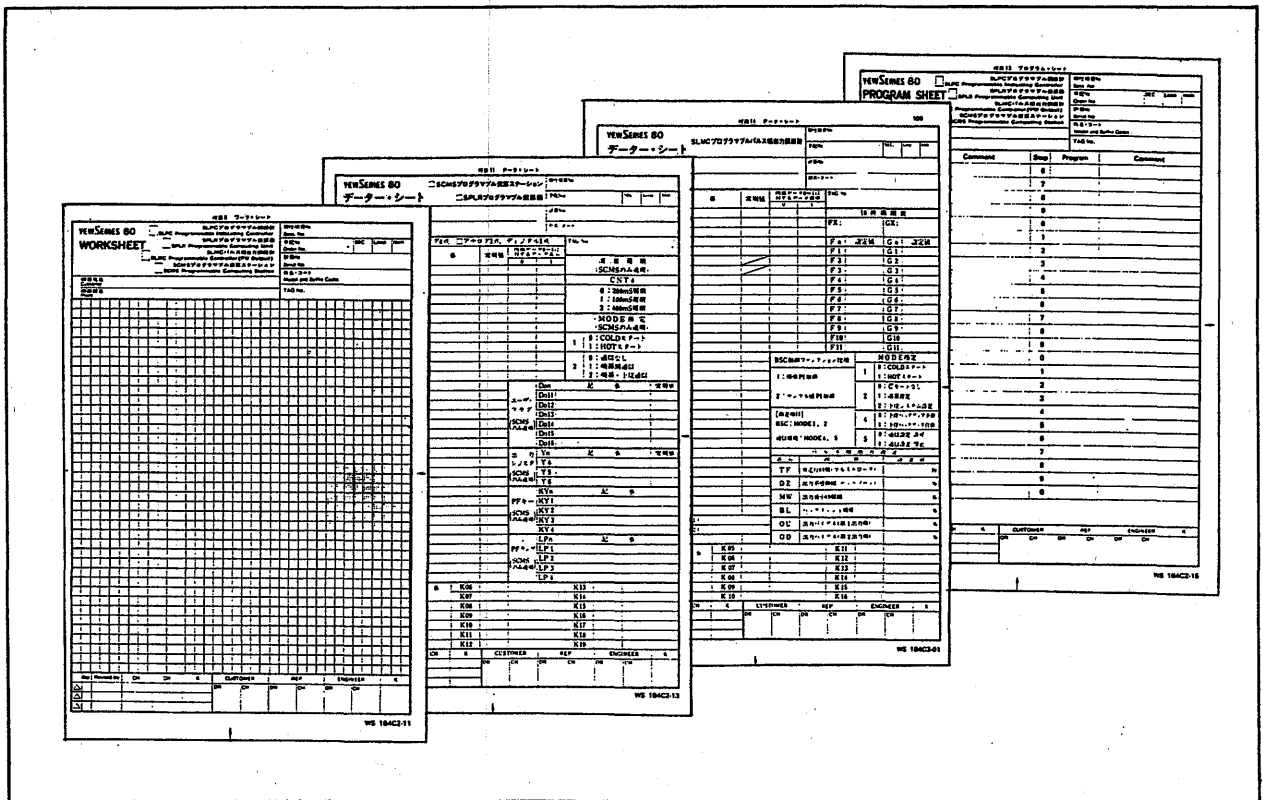
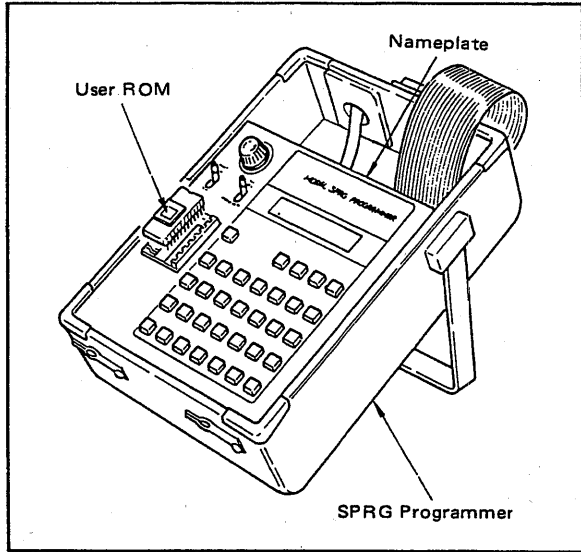

Figure 1-2-1. Sheet Forms Used in Step 1.

**Step 2: Instruction manuals related to loading programs in ROM.**

- ① SPRG Programmer Instruction Manual IM 1B4W1-02E.
- ② Functions and Applications of YEW SERIES 80 Programmable Instruments: TI 1B4C2-02E.



**Figure 1-2-2. User ROM and SPRG Programmer.**

**Step 3: Install the ROM in the SCMS and proceed to operations.**

This instruction manual covers the operations for step 3.

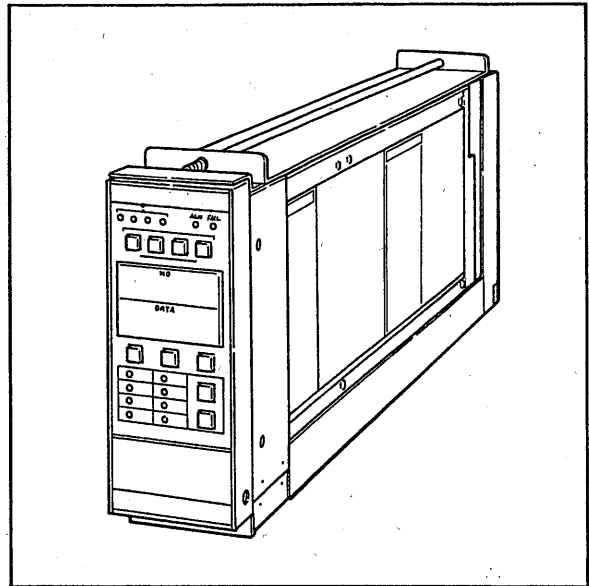

**Figure 1-2-3. SCMS Programmable Computing Station.**

## 2. GENERAL.

The SCMS Programmable Computing Station is a panel mounting instrument which demonstrates powerful performance in general computation and sequence logic operation and is excellent in supervisory functions and operability.

It is capable of performing various types of analog signal computation including four rules of arithmetic operation, square root extraction, selector, limiter, line-segment functions, dead time, moving average, program setting functions. It is also provided with sequence logic functions such as status I/O, logic operations, conditional jump and sub-program jump instructions.

Sophisticated control loops can be constructed by being combined with controllers since signal computation is freely combined with controllers since signal computation is freely combined with sequence logic and inter-instrumental communication with SLPC\*E or SLMC\*E is possible.

It is one of the outstanding features that programming is as simple as the desk top electronic calculator does. Users can create programs pleasingly.

### 2-1. Standard Specifications.

#### Input/Output Signals.

**Analog Inputs:** 1 to 5V DC, 4 points

**Analog Outputs:** 1 to 5V DC, 2 points. 4 to 20 mA DC, 1 point.

**Status I/O:** 10 points

**I/O Common Type:** Ten points can be freely specified either as inputs or outputs.

**Input:** Contact or voltage level signals

**Output:** Transistor contacts

**Fail Output Signal:** Transistor contact 1 point. Contact open during failure including power failure.

#### Display Functions.

**Data Display:** Data display lower section, in four digits

**Data Item Display:** Data items are displayed with lamps.

Item No. are displayed in the upper section of data display in two digit numerals.

**Bargraph Display:** The value in temporary register T01 is displayed with five segment LEDs.

**PF Lamp Indication:** 4 points

Lit/turned off with programs.

#### Setting and Operating Function.

**Data Calling Operation:** Item selection key

Item No. selection; Item No. selection key

**Variable Parameter Setting:** Select variable parameters (P<sub>N</sub>) and set with data setting key.

**PF key:** Four points.

### Computation Functions.

Category	Built-in-Functions
General Functions	Addition, Subtraction, Multiplication, Division, Square Root Extraction, Variable Low Cut Square Root Extraction, Absolute Value, High Selector, Low Selector, High Limiter, Low Limiter.
Function with Device Addresses	Ten Line-segment Function (Equal Time Interval), Arbitrary Line-segment Function, High Limit Alarm, Low Limit Alarm, First Order Lag, Dead Time, Velocity Computation, Moving Average Computation, Velocity Limiter, Time Signal Generator, Program Setting, Status Change Detection, Pulse Input Counter, Totalizer Pulse Output.
Logical Functions	Logical Product, Logical Sum, Exclusive OR, Negative Comparison, Branching, Conditional Branching, Branching to Sub Program, Signal Switching.
Others	Operation Register Exchange Operation Register Rotation.

Computation Period: 0.1, 0.2 or 0.4 Second

### Communication Functions.

One to one inter-instrumental communication is available with SLPC\*E or SLMC\*E.

**Inter-instrumental Communication Distance:** 100 m (328 ft)

**Communication Period:** 480 ms

### Mounting.

**Style:** Flush mounting with indoor vertical panels. Both separate and side-by-side mountings are available.

**Tilting:** Up to 75° back from vertical

**Wiring:** External signal wiring; ISO M4 (4 mm) screws on terminal board.

Power and ground wiring; JIS C8303 Two pole, three wire grounding device (UL498).

Cord length; 300 mm (11.8 inch)

**External Dimensions:** 182.5 mm high x 87 mm wide x 480 mm deep (7.2 x 3.4 x 18.9 inch)

**Weight:**

**Computing Unit Less Housing:** 3.0 kg (6.6 lb).

**Housing:** 2kg (4.4 lb) (except for mounting kit)

#### Normal Operating Conditions

**Ambient Temperature:** 0 to 50°C (32 to 122°F)

**Ambient Humidity:** 5 to 90% R.H. (non-vapor condensing)

**Power Supply:** Two versions, for "100 V" (standard) or "220 V" (option/A2ER). Both versions may use AC or DC, without change to the instrument:

Version	100V	220V
DC (polarity reversible)	20 to 130V	120 to 340V
AC (47 to 63 Hz)	80 to 138V	134 to 264V



**Maximum Power Consumption:**

- 317 mA (with 24V DC supply).
- 15.2 VA (with 100V AC supply).
- 18.9 VA (with 220V AC supply).

**2-2. Model and Suffix Codes.**

Model	Suffix code	Style code	Optional code	Description
SCMS	.....	.....	.....	Programmable computing station
	-100..	.....	.....	Always 100
Style Code		*E ..	.....	Style E
Optional Specifications			/NPR /UPR	Unprogrammed With user program
Common options			/A2ER	220V power supply
			/MTS /SCF- G□M	With mounting kit Bezel color change
			/NHS	Separate housing order
			/NPE	Engraving letters on the name plate on the front panel

**2-3. Optional Specifications.**

- /A2ER:** For "220V version" power supply.
- /NPR:** Station supplied unprogrammed. Specify this when user creates the user program using the SPRG programmer.
- /UPR:** Station supplied with standard program configuration. Specify when user is to ask for YOKOGAWA to create user programs.
- /MTS:** Station supplied with kit for separate mounting.
- /SCF-G□M:** Mounting kit bezel color change from standard color (black). Choose color from set of optional colors (see GS22D1F1-E). Specify color code in space □.
- /NHS:** No housing, instrument only. See GS 1B4F1-E to order housing separately.
- /NPE:** Specify when user asks for YOKOGAWA to engrave letters on the name plate on the front panel (using standard lettering characters).

**2-4. Accessories.**

- Fuse (1 A):** 1 piece.
- ROM:** 1 module. (When /NPR is selected in common options, the station will be supplied with blank ROM.)
- Part No.:** G9003LT
- Note:** The fuse (S9510VK) is the dedicated fuse, Do not use it for other products.

### 3. INSTALLATION.

For general information on installation and mounting, refer to Instruction Manual "Panel Instrument Mounting" (IM 1B4F1-01E).

#### 3-1. Wiring.

Connect external signal wires to the terminal board on the rear of the station housing with ISO M4 (4 mm) size screws. Remove the cover from the housing for access to the terminal board. Attach the cover in original position after wiring. (See Figures 3-1-1 and 3-1-2.)

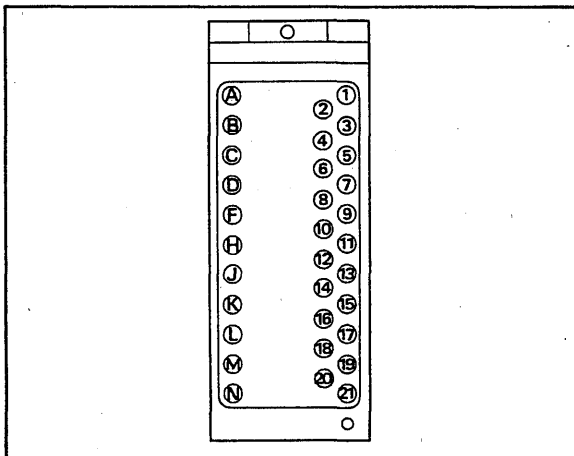

Figure 3-1-1. Terminal Layout.

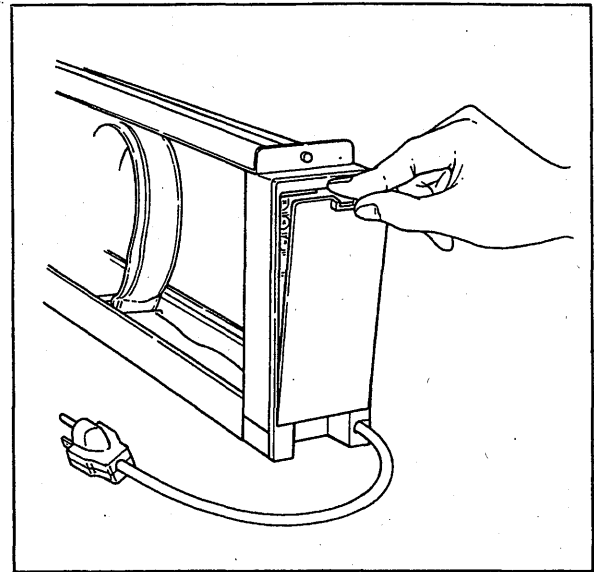

Figure 3-1-2. Terminal Board Cover.

Table 3-1-1 shows the terminal designations and signals to be connected to the SCMS Programmable Computing Station.

■ Terminal Connections

Table 3-1-1. Terminal Connections.

Terminal Designation	Description	Terminal Designation	Description
1	+ > Analog input 1	17	+ > Communications
2	- > Analog input 1	18	- > Communications
3	+ > Analog input 2	19	+ Status signal 8 (DI08/DO03)
4	- > Analog input 2	20	- Common 2
5	+ > Analog input 3	21	- Fail (negative terminal)
6	- > Analog input 3	A	+ > Analog output 1 (current output)
7	+ > Analog input 4	B	- > Analog output 1 (current output)
8	- > Analog input 4	C	+ > Analog output 2
9	+ Status signal 1 (DI01/DO10)	D	- > Analog output 2
10	+ Status signal 2 (DI02/DO09)	F	+ > Analog output 3
11	+ Status signal 3 (DI03/DO08)	H	- > Analog output 3
12	+ Status signal 4 (DI04/DO07)	J	+ > Status signal 10 (DI10/DO01)
13	- Common 1	K	- > Status signal 10 (DI10/DO01)
14	+ Status signal 5 (DI05/DO06)	L	+ > Status signal 9 (DI09/DO02)
15	+ Status signal 6 (DI06/DO05)	M	- > Status signal 9 (DI09/DO02)
16	+ Status signal 7 (DI07/DO04)	N	+ Fail (positive terminal)

3-1-1. Wiring Precautions.

- (1) Terminate wires in ring-type crimp-on terminals.
- (2) The proportion of status lines that are inputs and the proportion that are outputs can be set by the user program. The default is for status terminals 1 to 5 to be inputs and status terminals 6 to 10 to be outputs (Fig. 3-1-1).
- (3) Most of the I/O status signals share common negative (ground) terminals; for these signals, use external relays if I/O isolation is required.
  - For status signals 1 to 4, terminal 13 is the common (negative) terminal; for status signals 5 to 8, terminal 20 is the common (negative) terminal.
  - Status signals 9 and 10 are independent and isolated from other signals.
- (4) Provide contact or voltage-level status input signals which meet the specifications. Particularly take care that leadwire resistance (voltage drop in leadwires) is not excessive, and observe correct polarity for voltage inputs (Figs. 3-1-3 and 3-1-4).

Internal input status	ON	OFF
Status input signals		
For contact input	CLOSE (Signal source resistance: 200Ω or less)	OPEN (Signal source resistance: 100kΩ or more)
For voltage input	LOW (Input voltage -0.5 to +1V)	HIGH (Input voltage 4.5 to 30V)

- (5) FAIL and status outputs use transistor contacts. Pay attention to the following when they are connected to external devices. (See Figs. 3-1-5 and 3-1-6.)
  - The contact has plus and minus polarities, so do not to mistake them.
  - When switching devices with an inductance component such as relays, connect a surge absorber (such as a protection diode, CR circuit, etc.) in parallel with each load.
  - Because the transistor contact cannot directly switch the AC load, always use a repeating relay.
  - Do not connect a load exceeding contact rating (30V DC, 200mA or less)
- (6) For communication wiring, use special shielded SCCD twisted-pair cables for communications.

- (7) Short the current output terminals when they are not in use.

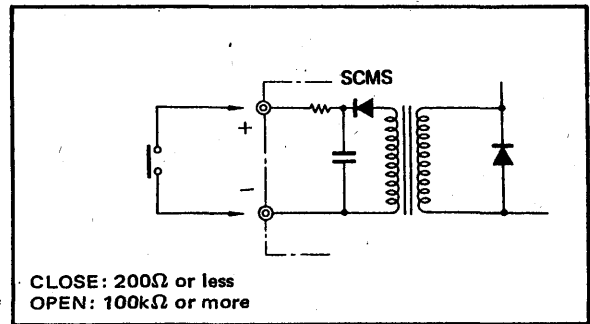

Figure 3-1-3. Status Input (Dry Contact).

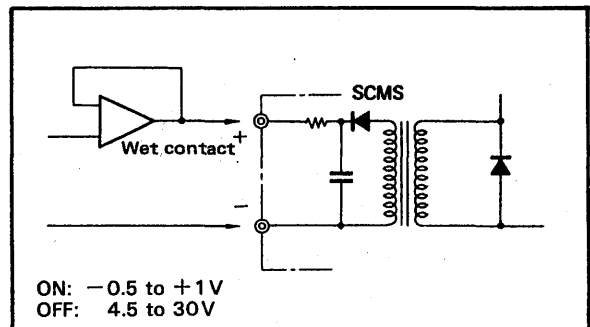

Figure 3-1-4. Status Input (Wet Contact).

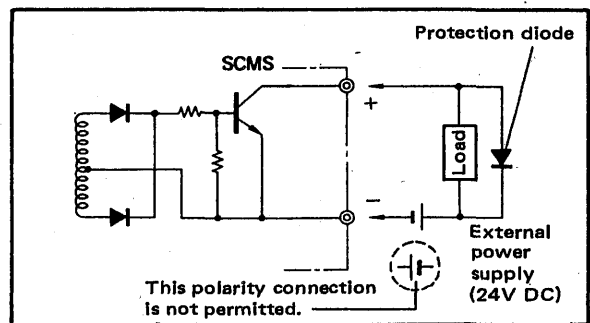

Figure 3-1-5. Connection When Status Output Is Used.

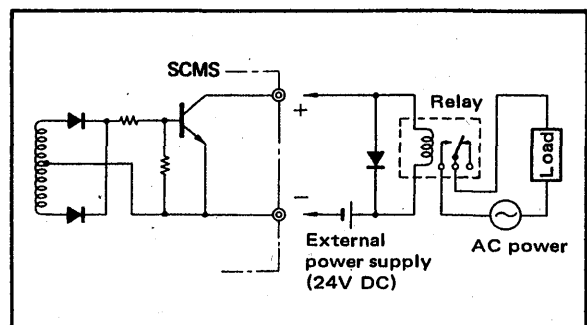

Figure 3-1-6. Connection of Status Output When Load Including AC Power Is Driven.

## 4. PRINCIPLES OF OPERATION.

### 4-1. Circuit Descriptions.

Figure 4-1-1 shows the SCMS circuit block diagram.

#### 4-1-1. Analog Input Circuit.

A voltage input signal enters the input circuit consisting of RIN, RI, and CI. RIN uses a high value of resistance (1 MΩ), so it normally does not affect circuit operation. However, if the input circuit opens (input disconnected), it provides a DC path between (+) and (-) input terminals to prevent the buildup of static charge on the (+) input line. This situation is equivalent to 0V DC input (-25% of range).

R1 and C1 form an input filter with a time constant of approximately 0.1 second.

All analog-input negative leads are connected to a common line inside the SCMS.

#### 4-1-2. Analog-to-Digital Converter Circuit.

Analog input signals entering the input circuit are sequentially selected by the input multiplexer. The comparator compares an input signal with the output of the digital-to-analog converter circuit, and the CPU adjusts the converter output so that the two signals are equal - basically, a successive-approximation type analog-to-digital converter. The corresponding digital value is stored in data memory (RAM).

#### 4-1-3. Status Input Circuit.

Each status input signal is isolated by a transformer in the input circuit. Input status is read via an input port and transmitted via the data bus to RAM.

At the same time as the status inputs are read, the switch statuses (SET, C/A/M, MV, TUNING, ACTION) on the instrument front and side panel are also read and stored in RAM.

#### 4-1-4. Digital Computing Circuit.

When all the input data is read, the microprocessor (CPU) performs data processing according to the computation program stored in user ROM.

The results of computation are output via the digital-to-analog converter circuit or output ports.

Inter-instrumental communication with SLPC\*E or SLMC\*E controller one to one is available. The communications line is isolated by a transformer.

The watch dog timer (WDT) connected to the CPU supervises the CPU operation - it causes the FAIL lamp to light and outputs a fail contact signal if the CPU fails. If the CPU fails, an output is obtained via FAIL contact.

#### 4-1-5. Analog Output Circuit.

The analog output signals, after digital-to-analog conversion, are fed via the output demultiplexer and buffer amplifier to the current and voltage output circuits.

The analog output signal negative line is common, and is connected directly to the analog input signal common negative line.

#### 4-1-6. Status Output Circuit.

The status output signals are transformer-isolated and output to the field through open-collector contact signals.

## 4-2. Principles of Computation.

### 4-2-1. Principles of Computation.

The SCMS performs three basic operations. It reads the input signal, computes, and outputs the computed result. The example in Figure 4-2-1 shows how to program the addition of two input signals. Figure 4-2-2 shows how the stack registers S change during the program. All computations are performed in the common stack registers S. Connection of signals to the registers - that is, input to the S registers - is performed by means of the LOAD (LD) instruction. The S registers, S1 thru S5, comprise a "stack," and data in S is pushed down (S1 to S2, S2 to S3, and so on) each time new data is input by the LD instruction.

Arithmetic operations can be performed on data thus input by using FUNCTION instructions. There are 46 types of computational FUNCTION instructions. These instructions are entered using their associated symbols, such as +, ÷, and HSL. The result of the computation performed on the necessary number of data stored in S registers is returned to register S1.

The STORE (ST) instruction is used to retrieve the result of computation and store it in an output register (to be described later). Execution of the ST instruction does not affect the contents of the S registers.

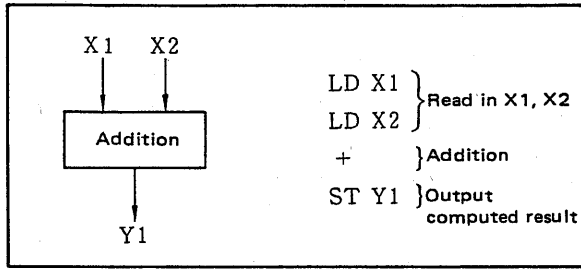

Figure 4-2-1. Two-Input Adder and Program.

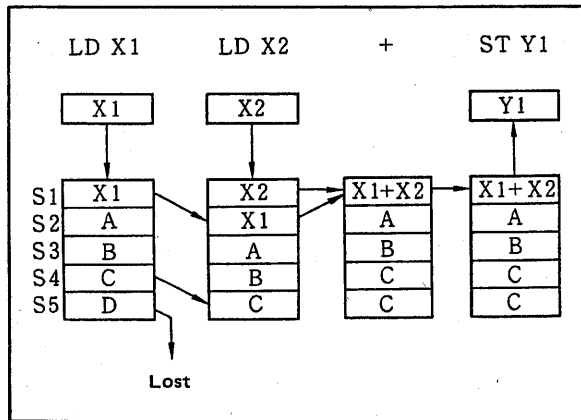

Figure 4-2-2. Behavior of Arithmetic Registers Associated with the Sample Program.

4-2-2. Input/Output Register Configuration.

Figure 4-2-3 shows the configuration of the SCMS's input/output registers. Analog, status, and set parameter inputs are read into registers  $X_N$ ,  $D_{IN}$ , and  $P_N$  before execution of the user program begins. The user program reads required input signals and parameters from the respective input registers into the arithmetic register using the LD instructions, and store the computed results in output registers  $Y_N$  and  $D_{ON}$  using ST instructions. Finally, the station outputs the contents of output registers  $Y_N$  and  $D_{ON}$  as analog or status values. This cycle repeats itself every 0.2 sec (0.1s or 0.4s).

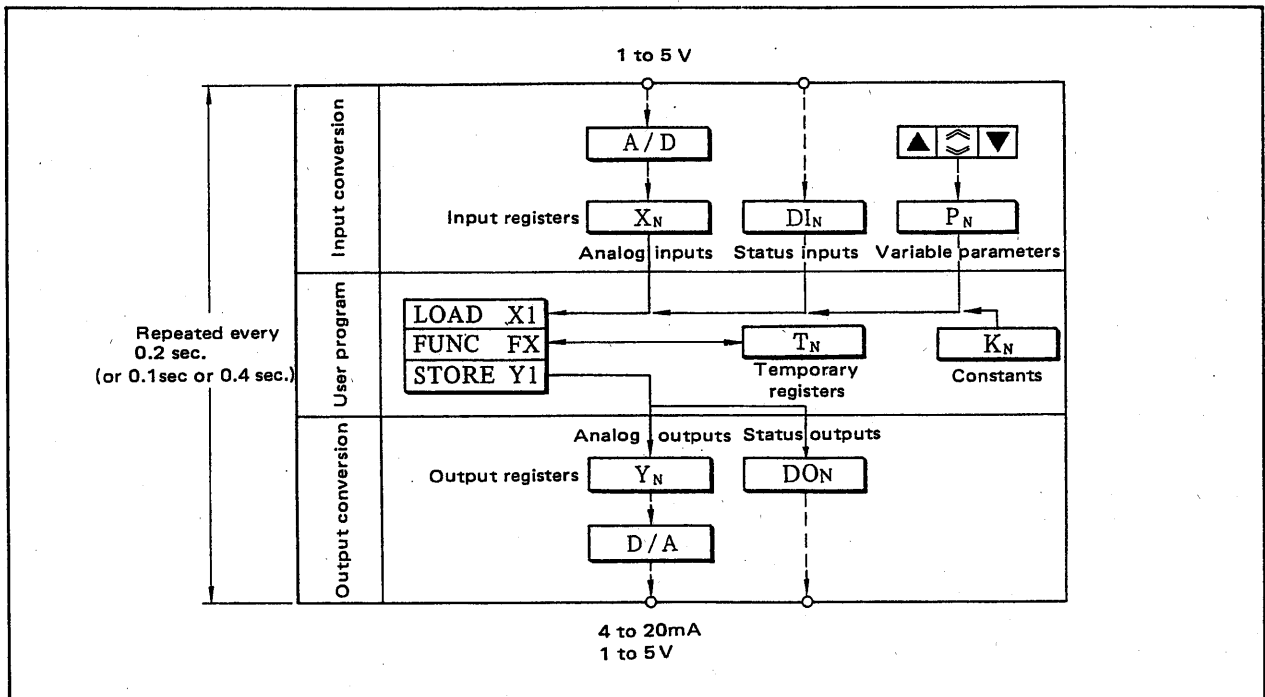

Figure 4-2-3. Input/Output Register Configuration.

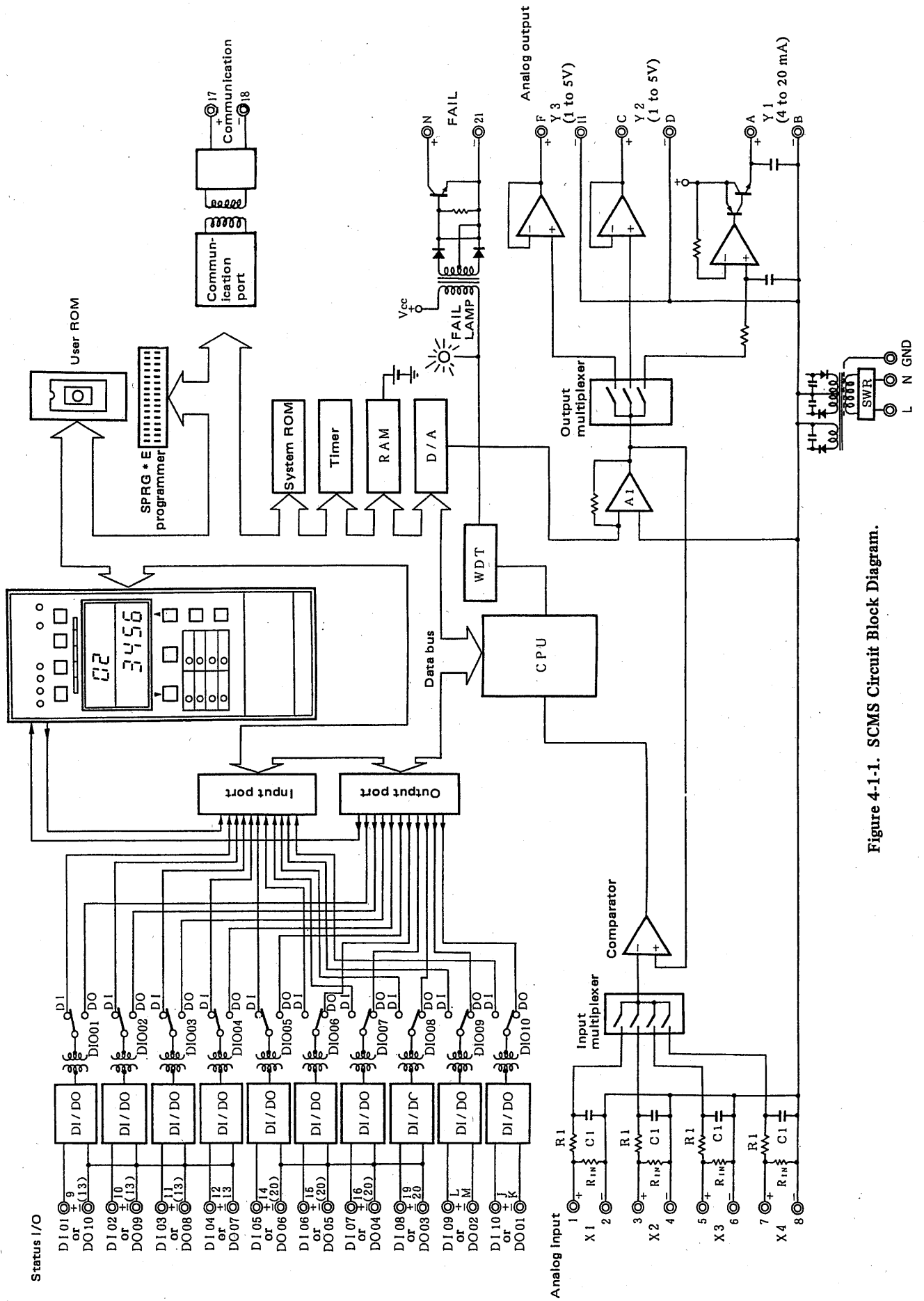

Figure 4-1-1. SCMS Circuit Block Diagram.



5. OPERATION.

5-1. Front-and Side-Panel Features.

5-1-1. Front-Panel Components.

Fig. 5-1-1 shows SCMS front panel components.

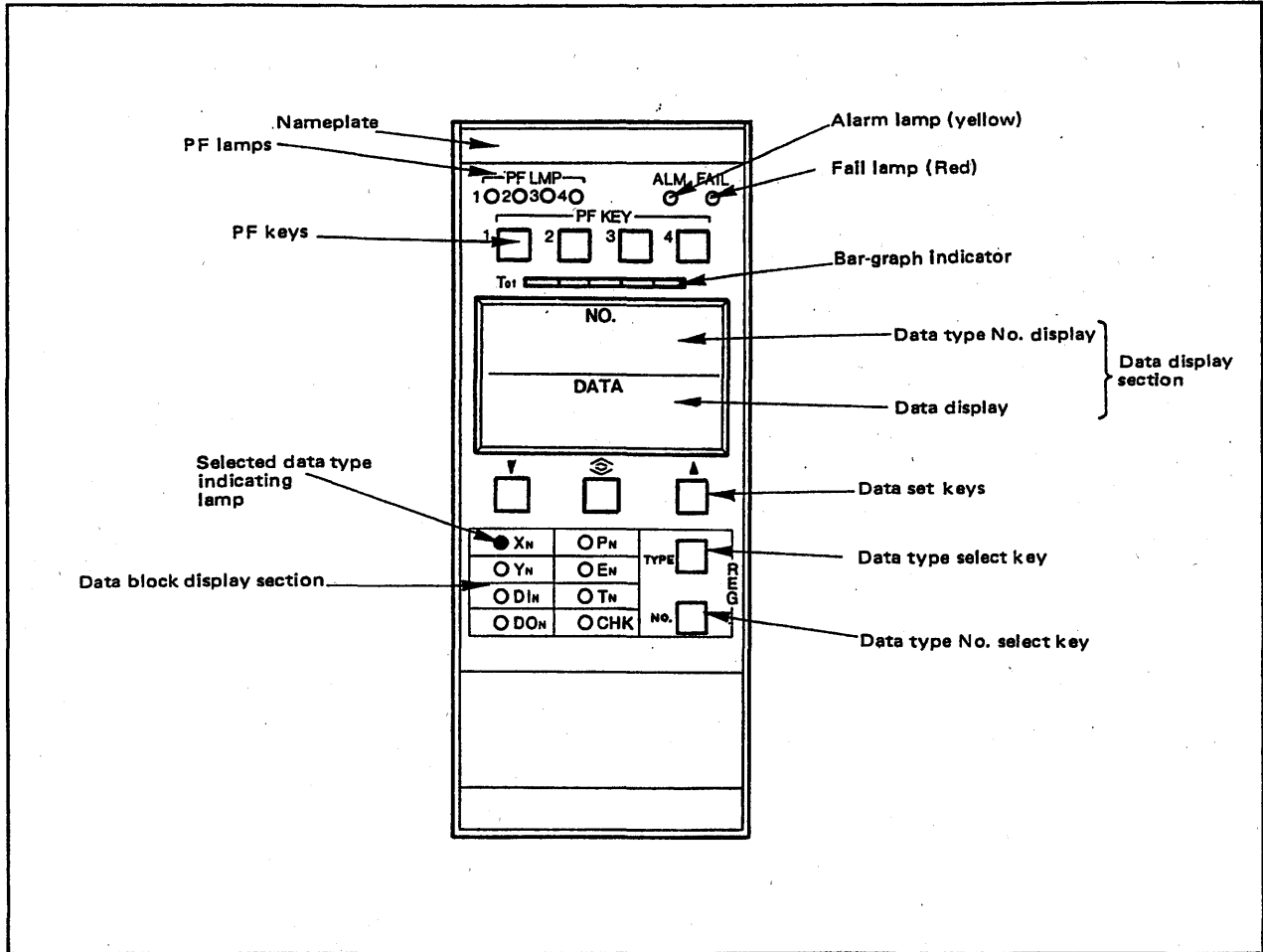

Figure 5-1-1. Front-Panel Components.

(1) FAIL lamp (FAIL)

Lights when the instrument fails.

(2) ALARM lamp (ALM)

Lights when an alarm condition is established, and flashes when the data memory backup battery is unloaded or its voltage drops.

(3) PF lamps (PF LMPs 1 to 4)

A program can light and extinguish these lamps. (Sequence progress state indication, etc.)

(4) PF keys (PF KEYS 1 to 4)

A program can designate these functions. (Sequence start and stop, etc.)

(5) Bar-graph indicator (T01)

Five LED's indicate values in the temporary storage register (T01) as a bar-graph.

(6) Data display

Upper display (NO.) Displays data type No. Selected by the data type select key (NO.)

Lower display (DATA): Displays data corresponding to data type No. Used also during variable parameter (PN) setting.

Tables 5-1-1. and 5-1-2. show display data types and their details.

(7) Data set keys (▼, □, ▲)

Used for variable parameter (PN) and operation mode (MODE) settings.

Settable only with the data set enable/inhibit switch (TUNING) on the side panel turned to



ENABLE. The operation mode is settable only with the data display select switch (SELECT) on the side panel turned to MODE.

Setting: To decrease data values, press the ▼ key.  
 To increase data values, press the ▲ key.  
 To increase data setting speed, press the  key simultaneously with the ▼ or ▲ key.

Data setting speed: 200 sec./100%  
 20 sec./100% (during increase in data setting speed)

**(8) Data type select key (TYPE)**

Used for data type selection.

Every time the key is pressed, the relevant lamp lights and each data type moves automatically as shown in Fig. 5-1-2, while the key is pressed.

No reverse movement is done.

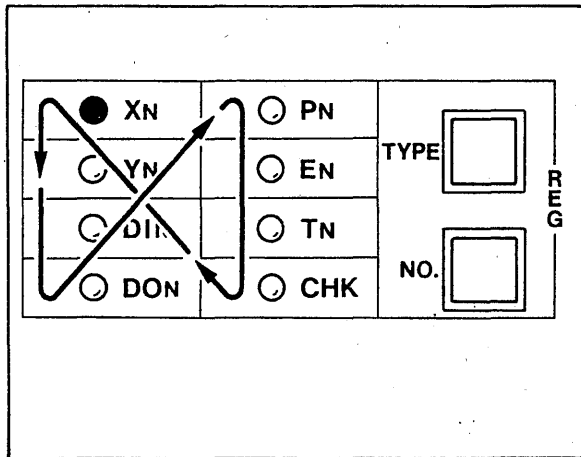

Figure 5-1-2. Select Data Type Movement.

Data display during key pressing  
 Upper display: Displays the selected data type head No. (01)

Lower display: Displays the relevant data  
(9) Data type No. select key (No.)  
 Used to select data type No.

Data type No. on the data display steps cyclically while the key is pressed.

No reverse movement is done.

**(10) Selected data type indicating lamp**

Indicates the data type selected by the data type select key (TYPE).

Extinguished with the data display select switch (SELECT) on the side panel turned to MODE, but no data type is selected at the front.

5-1-2. Side-Panel Components.

Fig. 5-1-3 shows SCMS side panel components.

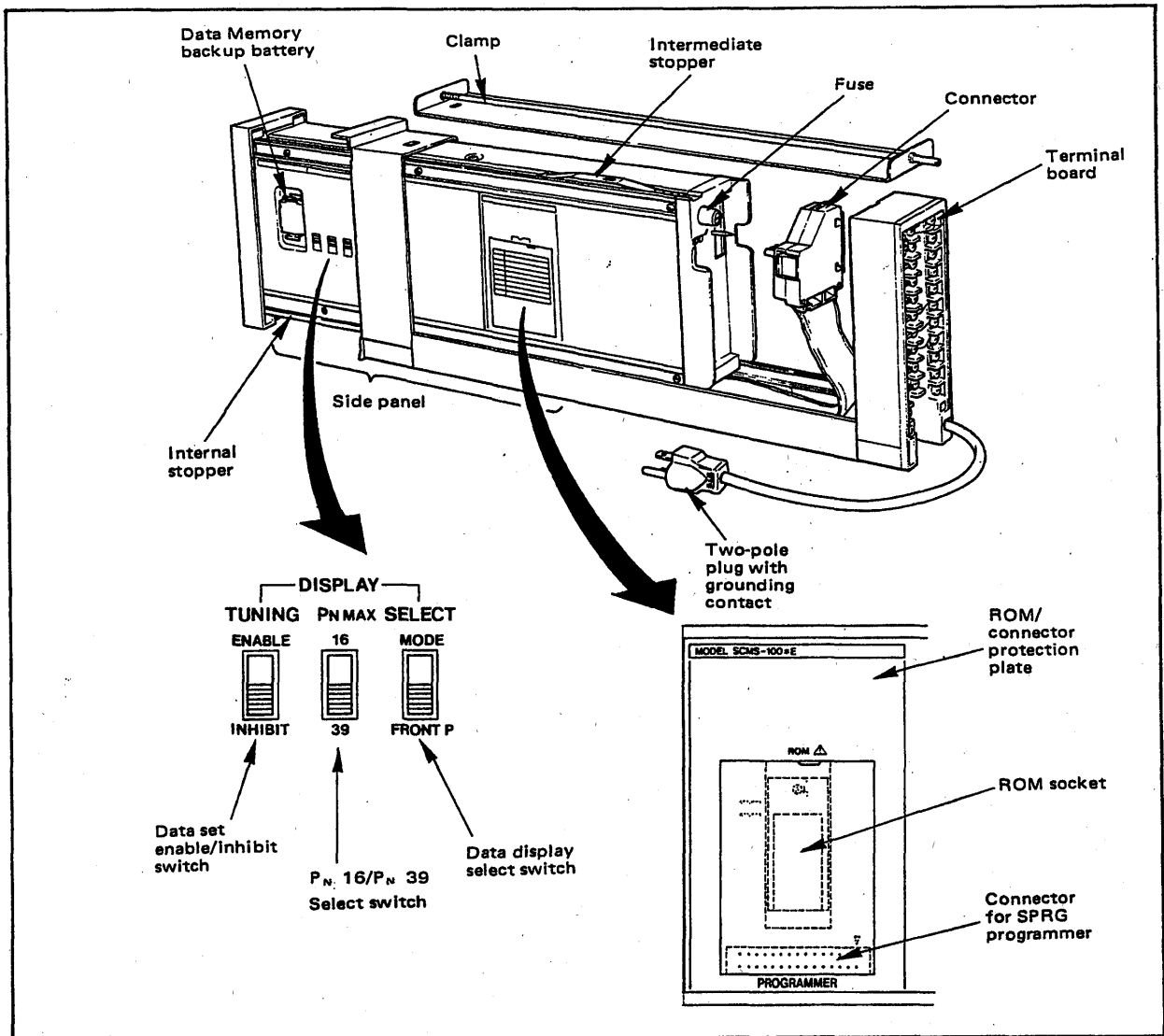

Figure 5-1-3. Details of Instrument Side and Side Panel.

(1) Data set enable/inhibit switch (TUNING)

Enables or inhibits data setting by the data set keys at the front.

ENABLE position: Enables data setting

INHIBIT position: Inhibits data setting

(2) PN 16/PN 39 select switch (PN MAX)

Displays variable parameters P20 to P39 for the program setting PGM1 and also selects required settings.

16 position: Display and setting of variable parameters, P01 to P16.

39 position: Display and setting of variable parameters, P01 to P39.

(3) Data display select switch (SELECT)

Selects data types to be displayed in the data display on the front panel.

MODE position: Displays the operation mode (Tables 5-1-2.)

FRONT P position: Displays data which can be selected at the front.

(4) ROM socket

Holds the ROM into which the user program is written. The ROM is secured when the socket lock is tightened while turning it clockwise. It is removed when the lock is turned counterclockwise.

(5) Connector for SPRG programmer (PROGRAMMER)

Connector for connecting programmer cables.

Table 5-1-1. Display Data Types and Details.

Data Type	Type No.	Name & Details	Display/Setting Range Figures in ( ): Default Value	Unit	Setting
X <sub>N</sub>	01-04	Analog input	In engineering unit	-	x
Y <sub>N</sub>	01 02, 03 04 to 06	Analog current output Analog voltage output Output register	In engineering unit In engineering unit In engineering unit	- - -	x x x
DI <sub>N</sub>	01 to 10	Status input DI <sub>N</sub> which is not designated as input: Always 0 [Display example] 	0/1	-	x
DO <sub>N</sub>	01 to 10 11 to 16	Status output } 4 DO <sub>N</sub> 's : Collective display User flag } (Same as DI <sub>N</sub> .) DO <sub>N</sub> which is not designated as output is displayed as user flag.	0/1	-	x
P <sub>N</sub>	01 to 08 09 to 16 20 to 29 30 to 39	Variable parameters Variable parameters PGM1 time setting PGM1 deflection-point output settings	In engineering unit (0.0) -800.0 to 800.0 (0.0) 0 to 9999 (0) -25.0 to 125.0 (0.0)	- % Sec. %	○ ○ ○ ○
E <sub>N</sub>	E01 to E15 CI01 to CI15 D01 to D15 CO01 to CO15	Communication analog input data Communication status input data Communication analog output data Communication status output data [Display example] 	-800.0 to 800.0 0/1 -800.0 to 800.0 0/1	% - % -	x x x x

Table 5-1-1. Display Data Types and Details (2/2).

Data Type	Type No.	Name & Details	Display/Setting Range Figures in ( ): Default Value	Unit	Setting
T <sub>N</sub>	01 to 16	Temporary storage register T01 data: Displayed on bar-graph	-800.0 to 800.0	%	x
CHK		Self-diagnosis, Displays the cause of the trouble in code.	See section 5.4.	-	-

Table 5-1-2. Operation Mode (MODE).

MODE	Initial Value	Set Status	Default Value
1 (Power recovery from failure)	0	COLD start The station is restarted in initial mode.	0
	1	HOT start The station is restarted with exactly the same mode and status it had immediately before the power failure.	
2 (Communications)	0	No communications made (SCMS operates independently.)	0
	1 (Note 1)	Inter-instrumental communications (Communications with SLPC*E or SLMC*E.)	
	2 (Note 1)	Inter-instrumental Communications with SLPC*E or SLMC*E which communicates with supervisory system.	

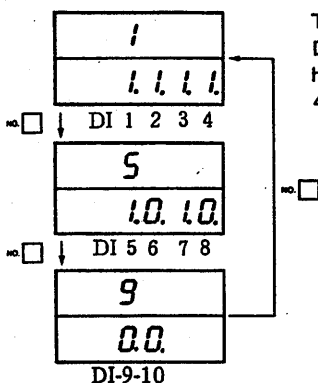
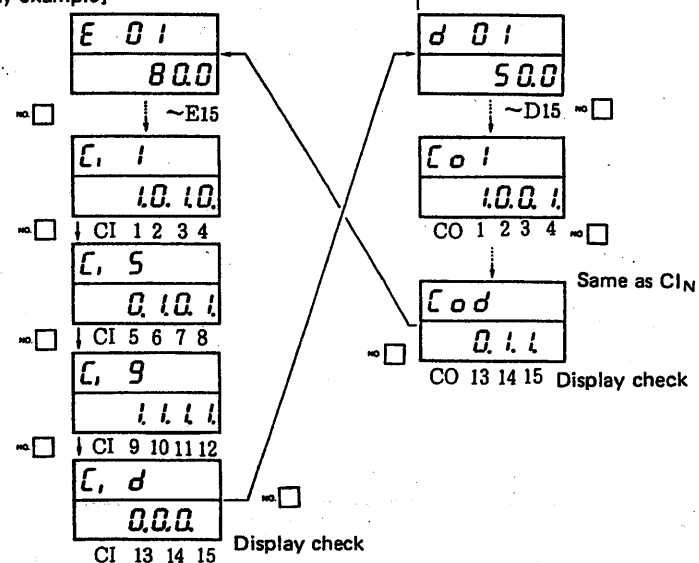
Note 1: If communication setting does not match communication wiring, no communications are made or a communication error occurs.

### 5-2. Preparations for Operation.

Make preparations with the instrument installed on the panel, or removed and placed on a work table. (With the instrument accommodated in its housing.)

#### 5-2-1. How to Draw Out the Internal Assembly from the Housing

- ① Pull out the internal assembly by pushing up the stopper while holding the bottom front of the instrument with the fingers. When it is pulled out halfway, it is locked by an intermediate stopper. (Fig. 5-2-1)

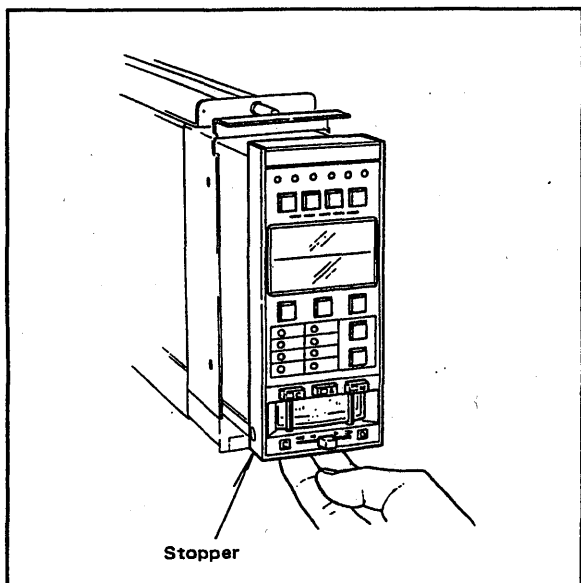

Figure 5-2-1. Pulling Out Internal Assembly.

- ② To remove the internal assembly from the housing, push down the intermediate stopper, then pull out the assembly as shown in Fig. 5-2-2.

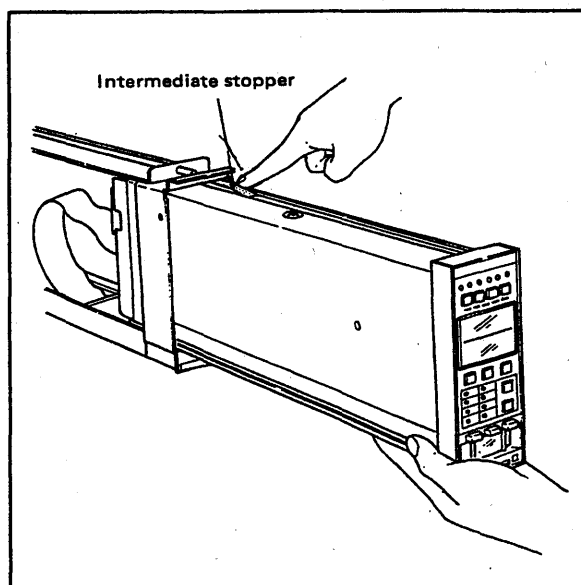

Figure 5-2-2. Removing Internal Assembly.

- ③ To separate the internal assembly from the housing, disengage the connector while placing the instrument front downward as shown in Fig. 5-2-3.

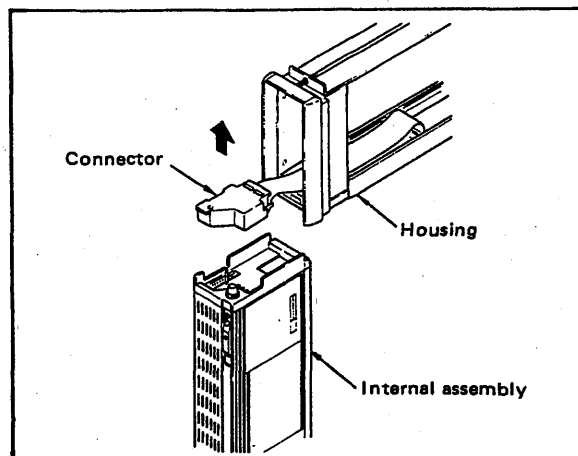

Figure 5-2-3. Separating Internal Assembly From Housing.

#### 5-2-2. Checking Installed Parts

Check that the fuse, the data memory-backup battery and the application ROM are fixed at the specified locations. Otherwise, install them in accordance with the procedure described later. (See Chapter 6 Maintenance.)

#### 5-2-3. Preparations for Operation

##### (1) Side panel setting

Set the DISPLAY switches on the side panel as shown in Fig. 5-2-4 and then turn power ON.

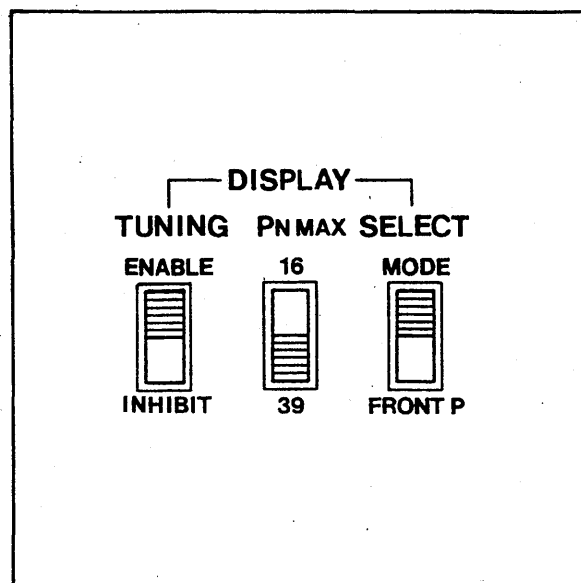



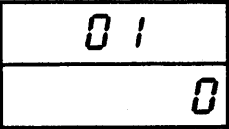

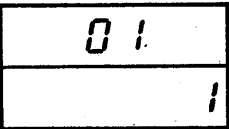
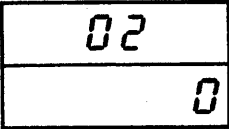

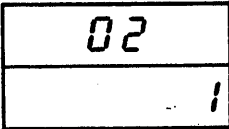

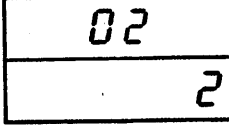

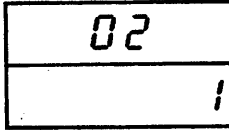
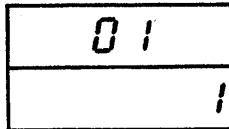

Figure 5-2-4. Setting Display Switches.

(2) Operation mode setting

First call up MODE's 1 and 2 using the data type select key (No.) at the front, and then set the data by the data set keys ( , ,  ). (The DISPLAY switches on the side panel should be set as shown in Fig. 5-2-4.)

[Display and setting example]

Key operation	Data display	Description
		MODE 1 Display ( 0 : COLD start 1 : HOT start Display just after the data display select switch is turned to MODE.
		0 → 1 If 0 is acceptable, go to the next step.
NO. <input type="checkbox"/>		MODE 2 Display ( 0 : No communications made 1 : Inter-Instrumental Communications 2 : Communications with SLPC*E (SLMC*E) which is communicating with supervisory system.
		0 → 1 If 0 is acceptable, the operation ends.
		1 → 2 If 1 is acceptable, the operation ends.
		2 → 1
NO. <input type="checkbox"/>		MODE 1 Display



The operation of these keys needs about 1 sec. (To prevent incorrect setting)

(3) Variable parameter (PN) setting

Turn the SELECT switch on the side panel to the FRONT P position. In addition, set the program setting PGM 1, in the program and place the PN MAX switch to the 39 position. (See Fig. 5-2-5.)

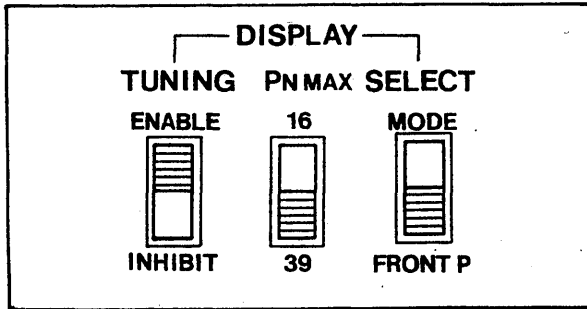



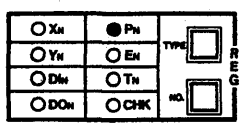
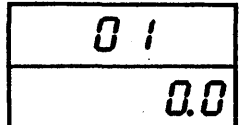

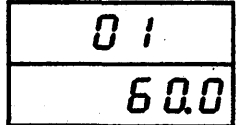

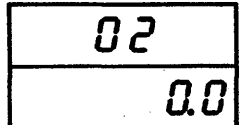

Figure 5-2-5. Setting Display Switches.

Call up PN by the data type select key (TYPE) at the front panel, and then display the data type to be set on the data display using the relevant data item No. select key (No.).

Set parameters using the data set keys ( , , and  ). Set all of the parameters necessary for computation.

[Display and setting example]

Key operation	Data block display/Data display	Description
TYPE 		Calling up P <sub>N</sub>
		Display of type No. 01 Display immediately after calling up P <sub>N</sub>
		 : Can also be used
NO. 		Display of other type No's. Type No's move cyclically while the No. key is continued to be pressed.

Each parameter display, setting range and engineering unit are as shown in the following.

- P01 to P08: Display in engineering unit.  
Display range of data written in in the user ROM.
- P09 to P16: -800.0 to 800.0%  
(Corresponds to internal data -8.000 to +8.000)
- P20 to P29: 0 to 9999 seconds
- P30 to P39: -25.0 to 125.0%
- P17 to P19: Missing No's.

**(4) Initial value, default value**

The initial value is that simultaneously written when the user program is written into the ROM by the SPRG programmer. When the value set by the data set key is lost due to failure of power and/or the battery, the initial value written in the user ROM is read as set data to start computation.

The default value is a value when the programmer and the parameter are initialized while connected with the SPRG. When you create a new user program, be sure to initialize the programmer and the parameter. (See Tables 5-1-1 and 5-1-2.)

**(5) Data label creation**

A data label is a list of data which can be displayed and set on the data display, PF lamps and PF keys.

Parameters determined, and PF lamp and key function names are described in its blanks.

The data label is attached at the end of this manual. Cut the label along the broken lines and then insert it into the pocket of the instrument side panel for reference.

**(6) Side-panel switch setting prior to operation**

Fig. 5-2-6. shows the SELECT switch positions on the side panel during normal operation.

Set these switches to these positions, prior to starting operation.

After all of the preparations have been finished, disconnect the power plug, and then install the instrument on the panel to conduct signal wiring and turn the power ON.

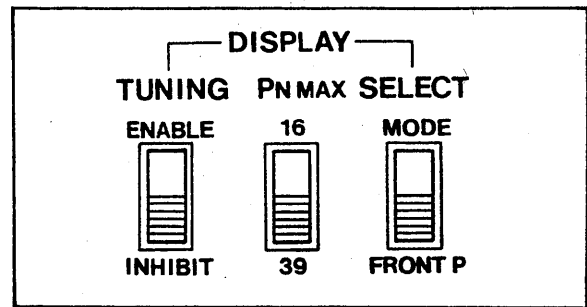

Figure 5-2-6. Display Switch Positions During Normal Operation.

**Unused Signals and Parameters**

Even input and output signals and parameters which are not used in the application program can be "called up" and "set" through key operation.

However, these data have no relation to computing and do not interfere with computation.



### 5-3. Startup and Operation.

This instrument starts computing program execution when power is turned ON.

Execute the functions assigned to the PF keys such as sequence stop and start, etc. in accordance with the programmed procedure.

#### 5-3-1. Data Display.

Display the data in the following steps.

- ① Data type calling up  
Data type select key (TYPE)
- ② Data type No. calling up  
Data type No. select key (No.)

See Table 5-1-1 for data types to be displayed and their details.

#### 5-3-2. Parameter Setting.

When a parameter setting change is required, pull out the internal assembly to turn the TUNING switch to the ENABLE position and then take the steps shown below.

- ① Data type PN calling up  
Data type select key (TYPE)
- ② Data type No. calling up  
Data type No. select key (NO.)

#### ③ Data setting

Data set keys ( ,  and  )

For details, see subsection 5-2-2(3).

After data setting, turn the TUNING switch to INHIBIT to prevent setting mistakes due to incorrect operation.

### 5-4. Actions to be Taken When FAIL and/or ALM Lamp Are Lit.

This instrument indicates failures occurring in the instrument and signals by FAIL and/or ALM lamps at the front panel. When any of these lamps light up or start flashing, immediately take the appropriate measures.

#### 5-4-1. For FAIL Lamp Lit.

FAIL lamp lighting means that there is critical trouble in the instrument.

In this case, analog and status outputs are held to the values immediately before the FAIL occurred. (However, abnormal values may be held depending on where the trouble occurred.)

The outputs tend to decrease slightly with time, but they can be backed up by using the SPBD stand-by manual station.

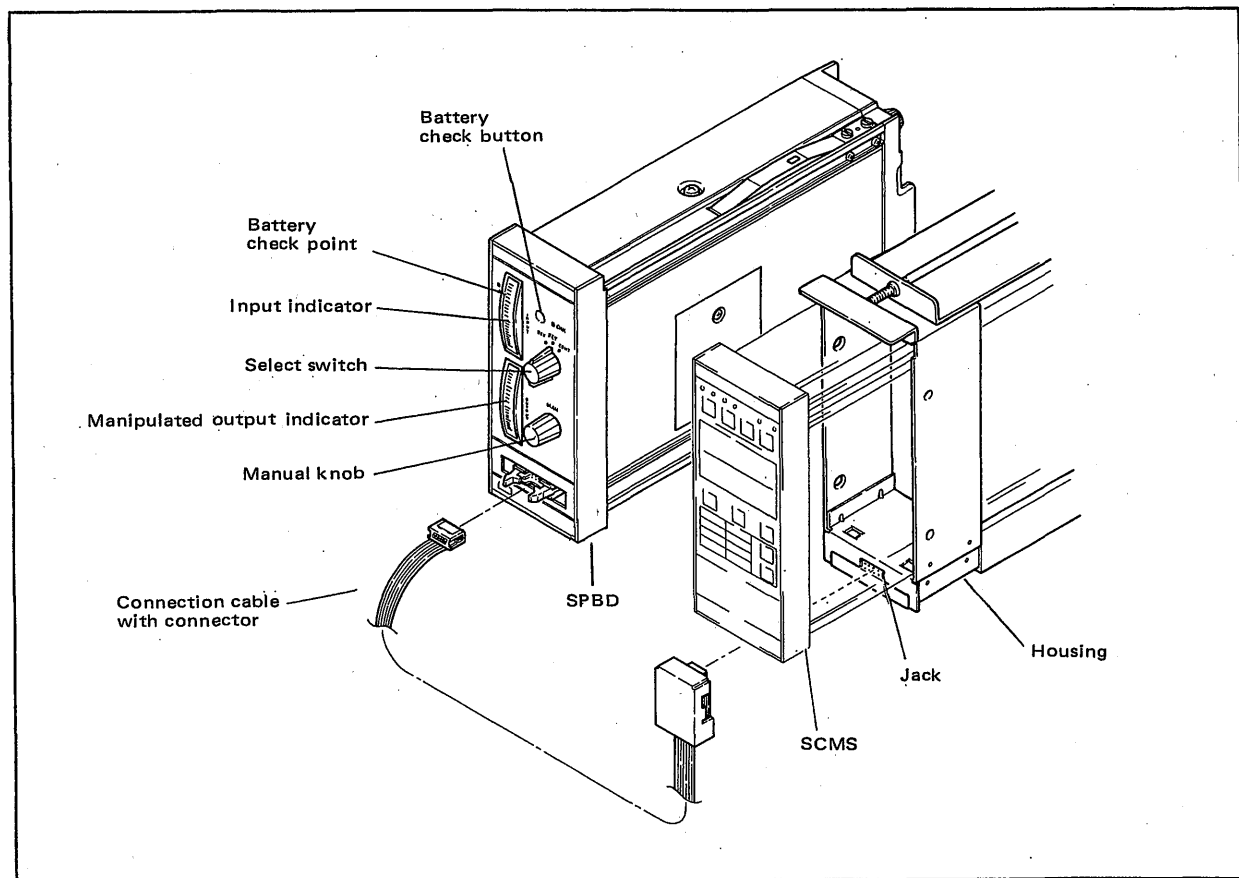

Figure 5-4-1. Connection to SPBD.

- (1) Connect the cable attached to the standby manual station SPBD to the jack at the bottom of the housing front to switch the current output signal to the SPBD from the SCMS. (See Fig. 5-4-1.)

For details of the SPBD operation, see the SPBD Instruction Manual (IM 1B4D5-02E).

- (2) Select CHK using the data type select key (TYPE) to check the cause of the trouble. Sub-section 5-4-4.) If it is estimated to be hardware failure, remove the instrument from the panel and then conduct instrument trouble shooting in accordance with the procedure in Chapter 7.

#### 5-4-2. For ALM Lamp Lit.

This lamp lights when input and/or output signal lines are disconnected. However, in this case, computing continues.

Select CHK using the data type select key (TYPE) to check the cause of the trouble. (See subsection 5-4-4.)

Take the appropriate measures according to troubleshooting in Chapter 7.

#### 5-4-3. For ALM Lamp Flashing.

If the data memory backup voltage drops, the ALM lamp starts flashing. In this case, replace the battery (See Item 6-3 for replacement procedure).

Notes:

- (1) If the ALM lamp starts flashing during normal operation, replace the battery as soon as possible.
- (2) Because ALM lamp flashing has priority over lighting, no other alarms are indicated during lamp flashing. (However, alarms can be indicated on the front display.)

#### 5-4-4. CHK Display.

The following table shows CHK display items.

Lamp	CHK Display	Diagnosis Details
—	00	Normal
FAIL	01	A/D converter trouble
FAIL	02	D/A converter trouble
ALM	04	Computing range overflow
ALM	08	Input signal range overflow
FAIL	10	User ROM unloaded or in trouble
ALM	20	Data memory backup battery unloaded or voltage drop (lamp flashing)
ALM	40	Current output signal circuit open or overloaded.
ALM	80	Internal data lost*
ALM	P.Error	Supply voltage too low.
FAIL	—	Instrument trouble (No display made.)

\*If the ALM lamp lights and CHK = 80 is displayed, the setting parameters are initialized. Therefore, check Pn and MODE on the data display and then re-set the parameters.

If more than one abnormality occurs at the same time, the sum of individually displayed values is shown in hexadecimal digits.

Example:

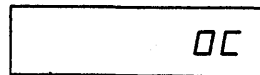

0C = 04 + 08 (Computed overflow, and input overflow result.)

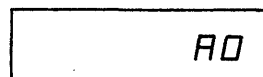

A0 = 20 + 80 (Battery failure and loss of data)

The displayed value returns to 00 if the cause of the relevant trouble is removed.

However, 80 (internal data lost) does not return automatically. Therefore, press the data type No. select key (No.) to return 80 to 00.

### 5-5. Connecting SPRG Programmer.

When changing the set data or computing programs, use the SPRG programmer.

For details of the SPRG operation, see the SPRG Instruction Manual (IM 1B4W1-02E).

Procedures for connecting SPRG to the SCMS are described in the following.

~~~~~  
**CAUTION**  
~~~~~

Do not connect or disconnect the SPRG connector during SCMS power-ON, under any circumstances.

#### 5-5-1. Connecting SPRG Programmer.

- (1) Turn both the SCMS and SPRG power OFF.
- (2) Set the SPRG to the PROGRAM mode.
- (3) Connect the SPRG cable connector to the SCMS. (See Fig. 5-5-1.)
- (4) Turn the SPRG power ON.
- (5) Turn the SCMS power ON.

**5-5-2. Disconnecting SPRG Programmer.**

- (1) Set the SPRG to the PROGRAM mode.
- (2) Turn the SCMS power OFF.
- (3) Turn the SPRG power OFF.
- (4) Disconnect the SPRG.

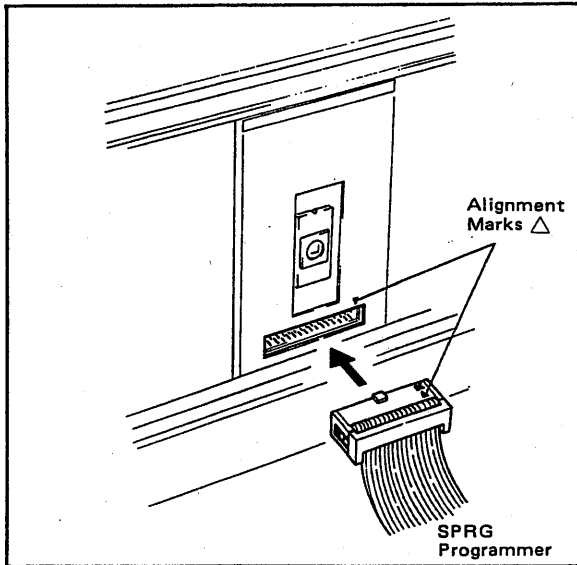

Figure 5-5-1. Connection to SCMS.

## 6. MAINTENANCE

Following is a description of comparatively easy part replacement.

### 6-1. Nameplate for Tag Label Replacement

Pull the internal assembly out slightly and then open the cover on the top of the front panel to pull out the nameplate. Insert a new nameplate. (Fig. 6-1-1.)

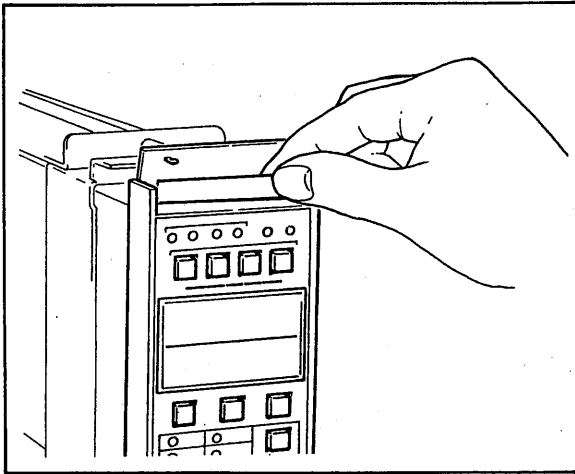

Figure 6-1-1. Nameplate Replacement.

### 6-2. Fuse Replacement

When an instrument trouble is caused by the fuse, check for contamination in the fuse holder or for an imperfect fuse contact. (Fig. 6-2-1.)

Recommended replacement frequency: about 3 years

(1) To replace the fuse, turn the fuse holder cap in the direction of the arrow (left) marked on the cap to expose the fuse, then remove it.

(2) Before replacing the fuse, check its rating.

After replacing the fuse, make sure the cap is screwed tight.

Note: Use the dedicated fuse (S9510VK). Do not use a fuse for other products.

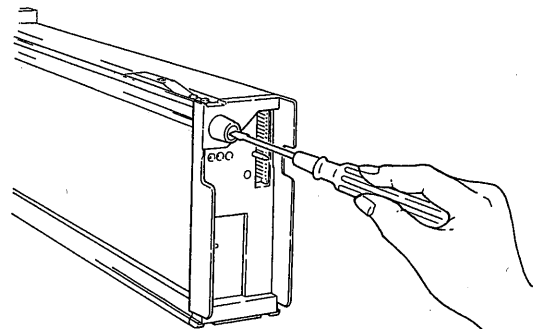

Fuse Part No.: S9510VK  
Rating : 1A

Figure 6-2-1. Fuse Replacement.

### 6-3. Data Memory Backup Battery Replacement.

If the ALM lamp on the instrument front panel starts flashing, replace the battery as soon as possible. Recommended replacement frequency.

About every 5 years: (When used with power turned ON, and at an ambient temperature of 45°C or less)

About every year: (When used with power turned OFF and at an ambient temperature of 45°C or less)

#### CAUTION

Always replace the battery with the power turned ON. Battery removal during power-OFF may lose the set date.

- (1) Pull out the internal assembly from the housing, and then remove the battery cover and the battery. (See Figs. 6-3-1 and 6-3-2.)
- (2) Load a new battery and then tightly close the cover.
- (3) Check that the ALM lamp at the instrument front stops flashing.

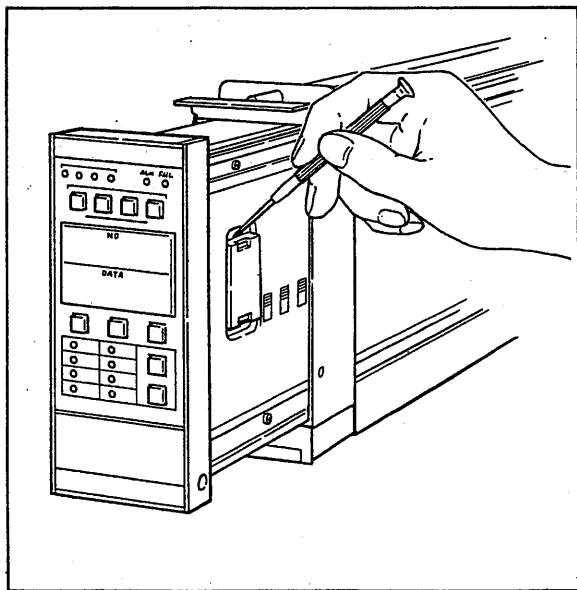

Figure 6-3-1. Protection Cover Removal.

#### [Data Memory Backup Battery Storage and Handling Precautions]

- (1) Storage conditions
  - Ambient temperature: -10 to 60°C (14 to 140°F)
  - Humidity: 5 to 95% RH (No condensation allowed.)
  - No corrosive gases.
- (2) Do not replace battery itself.
  - When replacing the battery, make sure to carefully check polarity by referring to the markings on the battery case.
- (3) When measuring battery voltage, always use a voltmeter with high input resistance. Do not use a circuit tester or multimeter.
  - Voltage: 2.45V or more
- (4) Handling prohibitions
  - Charging
  - Putting the battery into a fire or heating it.
  - Shorting between the positive and negative electrodes.
  - Incorrect loading mistaking positive and negative electrodes.
  - Strong shocks, Disassembly

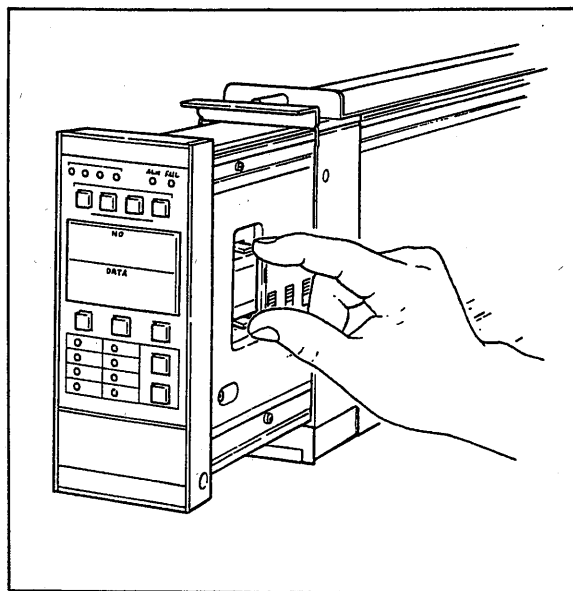

Figure 6-3-2. Battery Removal.

### 6-4. User ROM Replacement.

~~~~~  
**CAUTION**  
~~~~~

Do not attempt to install or remove the user ROM while the station is energized; otherwise, the station may switch to FAIL mode, and the ROM may be broken.

**(Notes in Handling User ROM)**

The user ROM is an PROM – a MOS (metal oxide semiconductor) IC. This type of IC must be handled carefully, as it may be damaged by static electricity. Note also that the program written into it will be lost if the ROM is exposed to ultraviolet rays through the window on the top of the device.

Observe the following precautions when handling the user ROM:

- **Cautions against Static Electricity**

Be sure to use a conductive mat when carrying and storing the PROM device. Do not bring it into contact with clothes and other substances that can be charged easily.

Do not handle the PROM using chemical fiber gloves.

- **Protect from Ultraviolet Rays**

Do not remove the seal from the PROM except when it is necessary to erase its contents.

When installing a new PROM in the controller, be sure to affix the specified seal to it.

- **Do Not Deform Pins**

If the pins are deformed, correct their geometry while being careful not to apply force to the base of the pin.

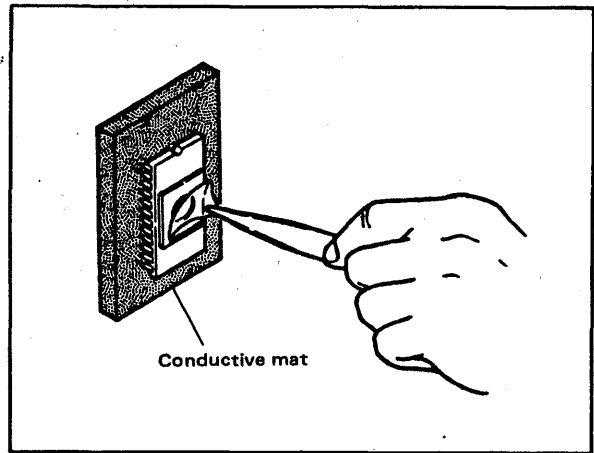

Figure 6-4-1. ROM Seal.

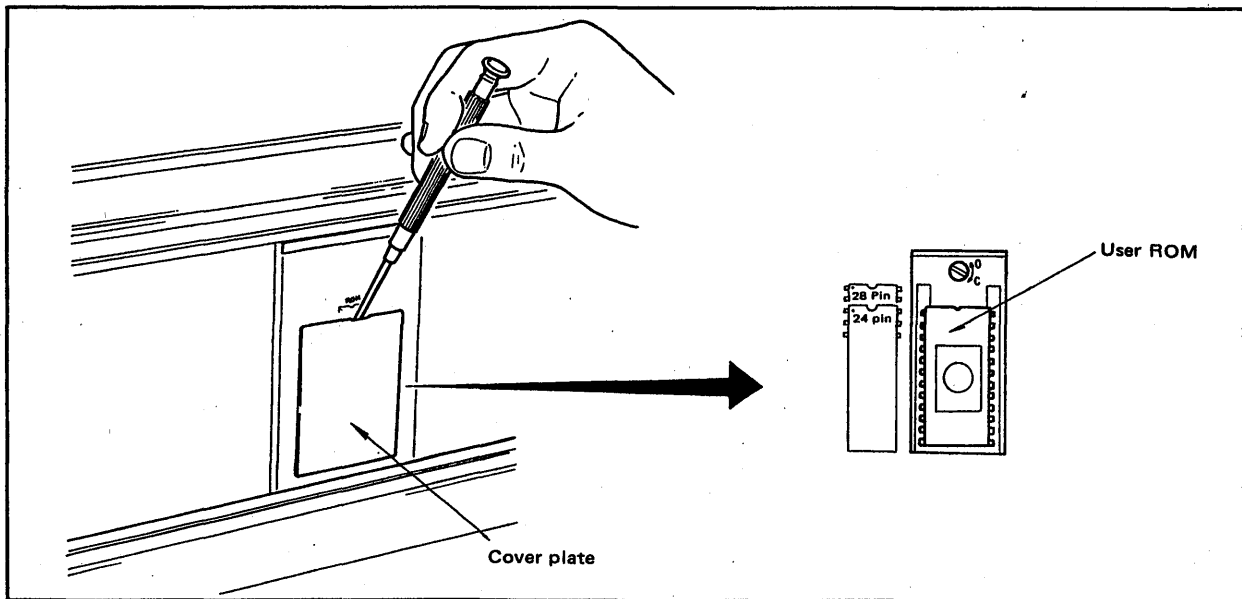

Figure 6-4-2. Removing Tuning Panel Cover Plate and ROM.

To replace the user ROM to support program changes, proceed as follows:

- (1) Removing user ROM
  - a. Turn off power to the station. (Leave the data memory backup battery in position.)
  - b. Remove the tuning panel cover plate; the user ROM will be exposed. (See Figure 6-4-2.)
  - c. Give  $\frac{1}{4}$  turn counterclockwise to the ROM lock section of the ROM socket (Figure 6-4-2).
  - d. Grasp the ROM manually and pull it out of the socket, being careful not to deform the pins. (See Figure 6-4-3.)
- (2) Installing user ROM
  - a. Turn off power to the station (Leave the data memory backup battery in position.)
  - b. Install the new ROM with its recessed window facing up.
  - c. Insure that the ROM pins are correctly aligned with their corresponding socket positions.
  - d. Press the ROM carefully into position.
  - e. Turn the ROM lock of the ROM socket with a small standard screwdriver until the rotation stops (about  $\frac{1}{4}$  turn).

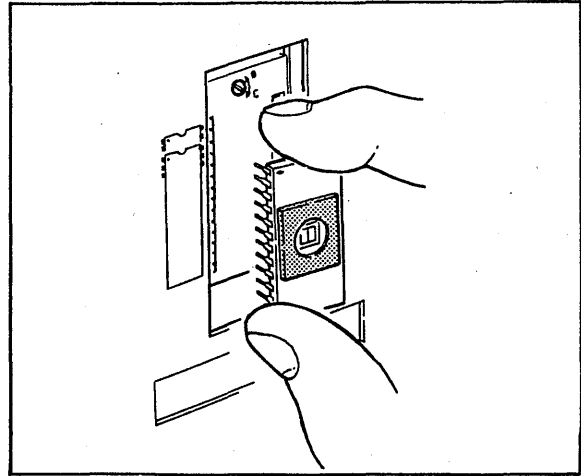

Figure 6-4-3. Removing ROM.

### 7. TROUBLESHOOTING.

If operational troubles occur, identify the problems fully and resolve them according to the troubleshooting flowcharts shown in Section 7-1. Troubleshooting can be facilitated by the use of the exten-

sion cable contained in the service kit (SSKD).

When the trouble is difficult to locate, consult the YOKOGAWA service station serving your area.

#### 7-1. Troubleshooting Flowcharts.

##### (1) Problem Identification

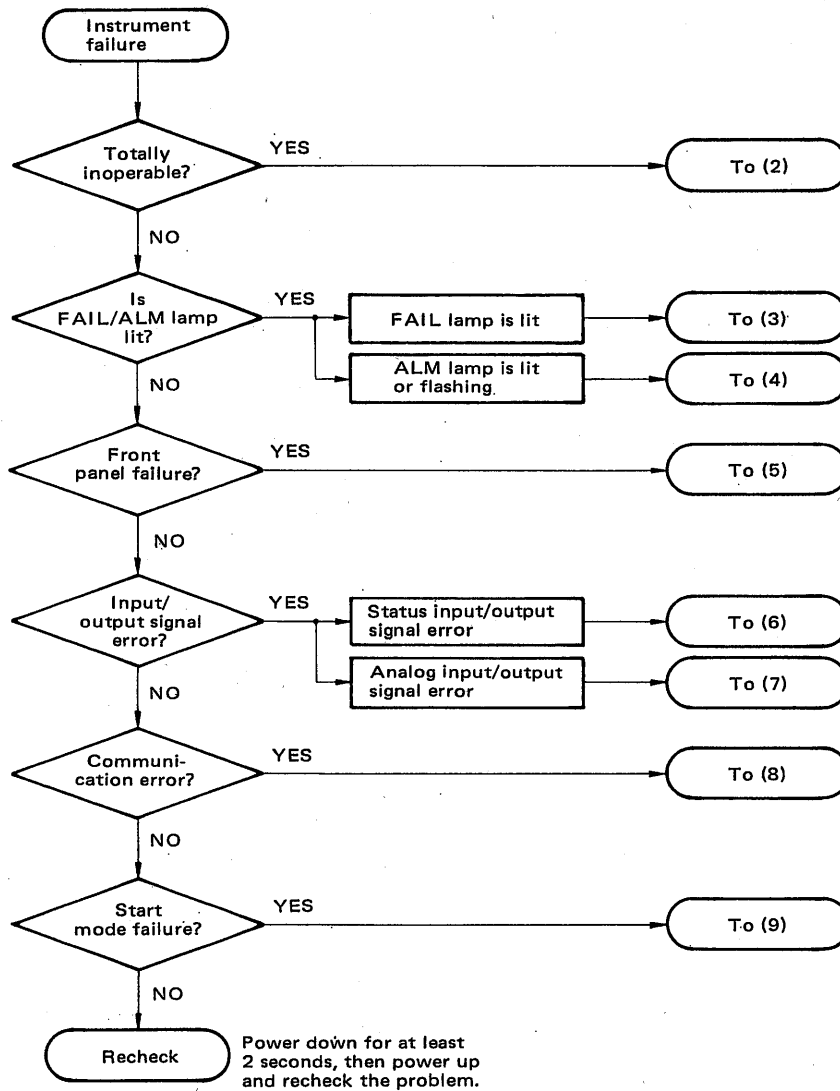



(2) Totally Inoperable

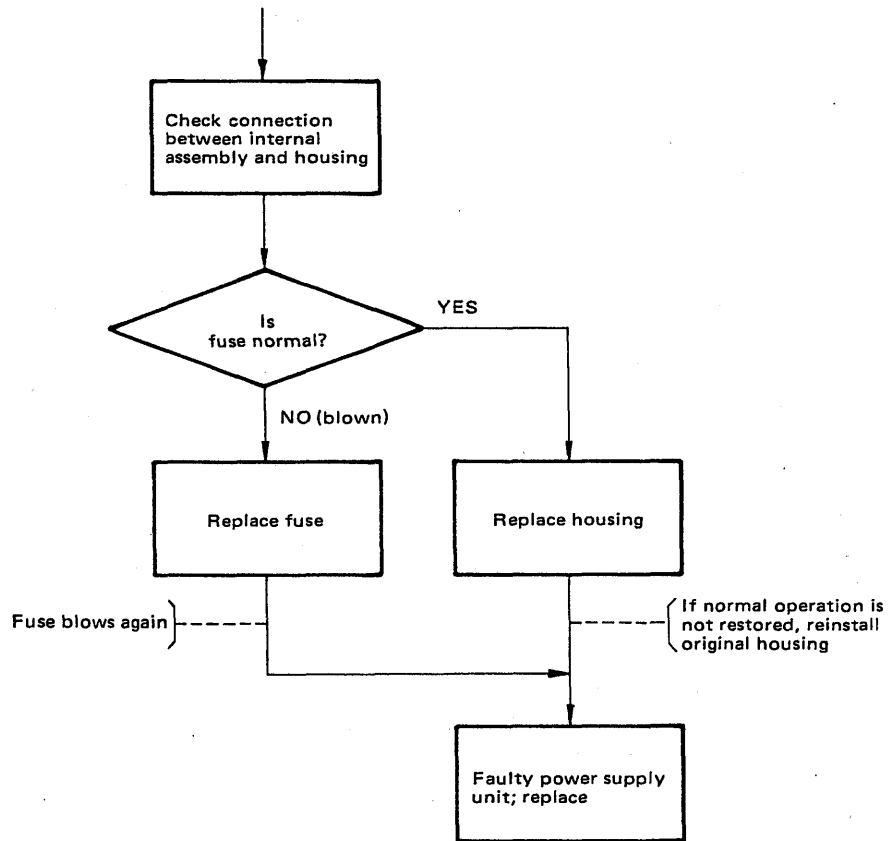

(3) FAIL Lamp is Lit

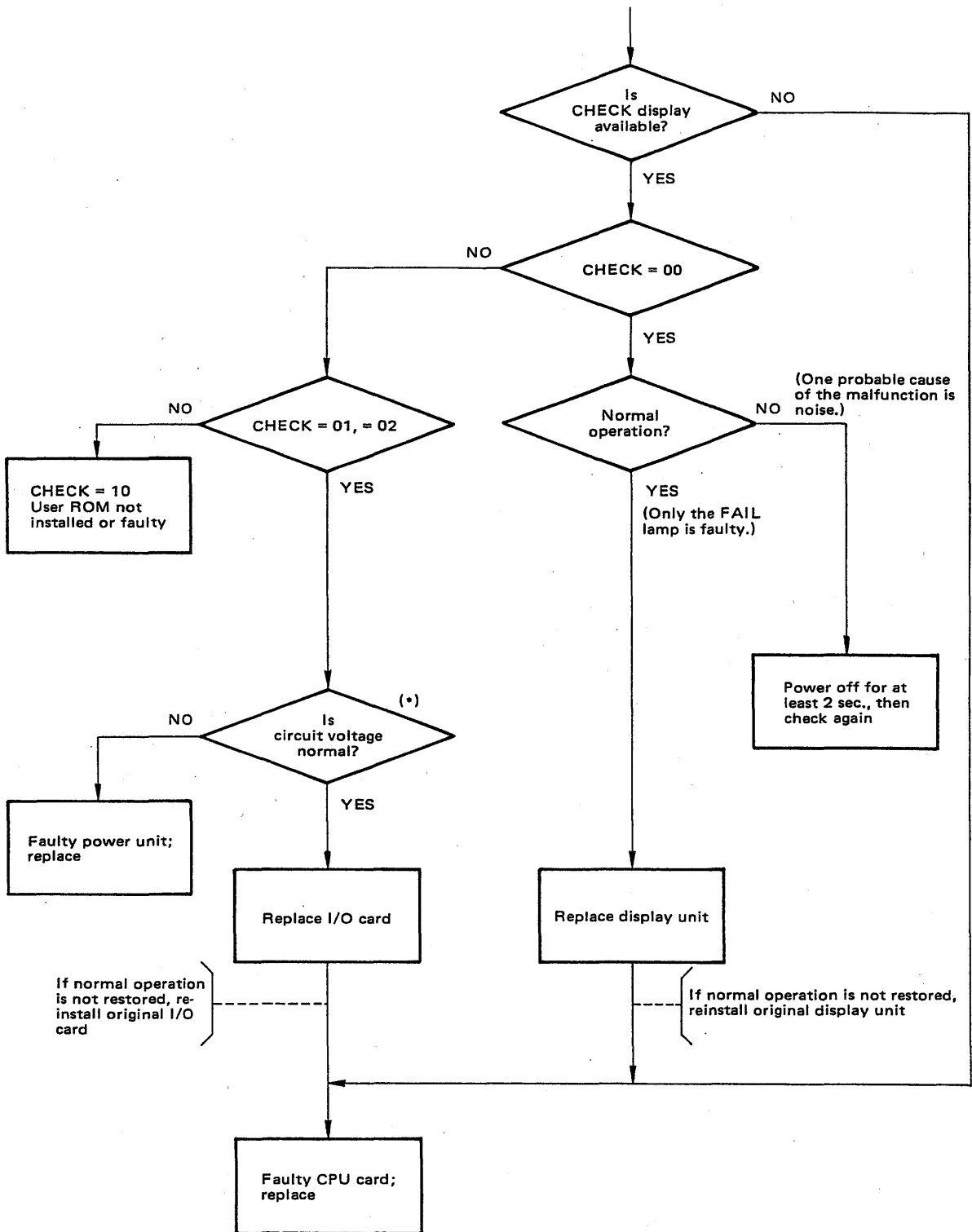

\* Check to see that the voltage across user ROM pins 12 and 24 is in range 4.8 to 5.2 V.

(4) ALM Lamp is Lit or Flashing

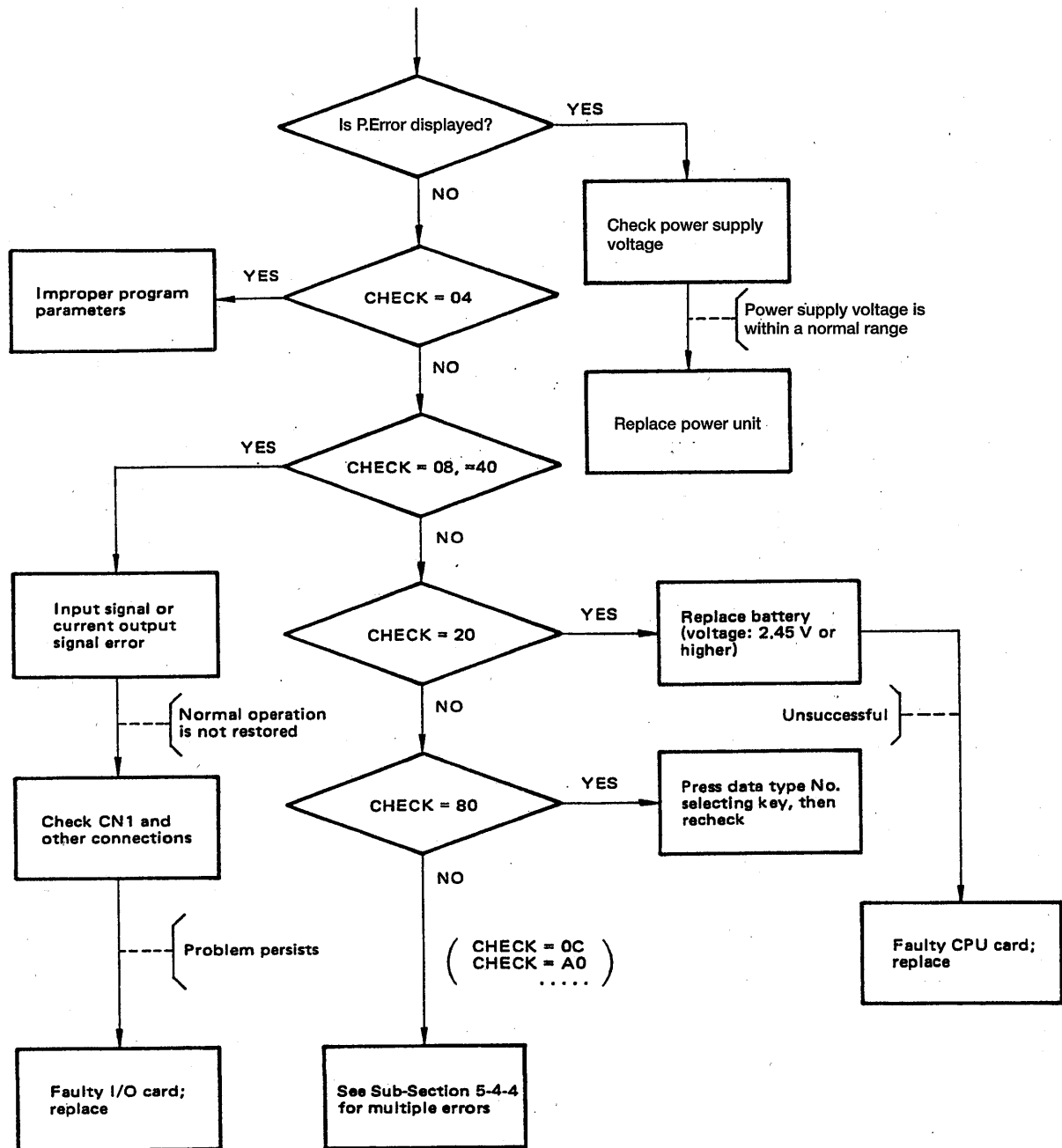

(5) Front Panel Failure

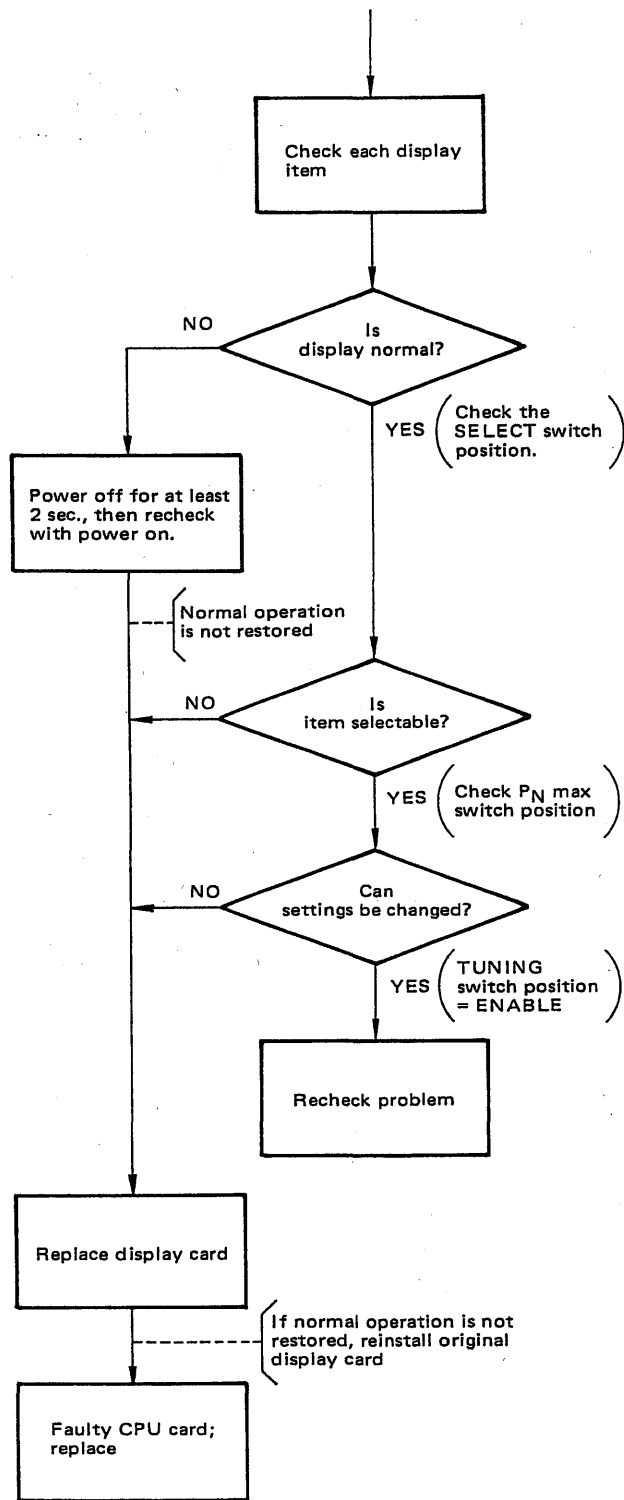

(6) Contact Output Signal Error

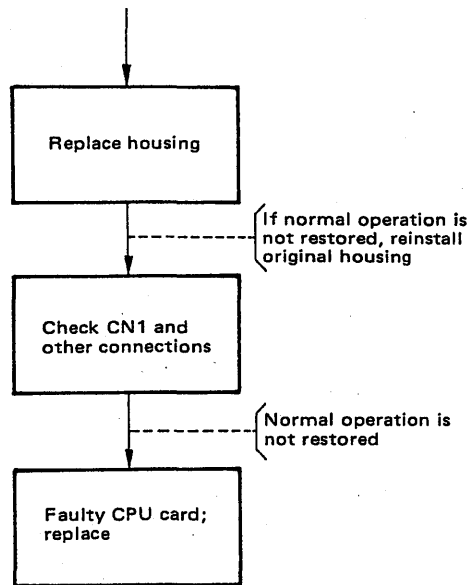

(7) Analog Output Signal Error

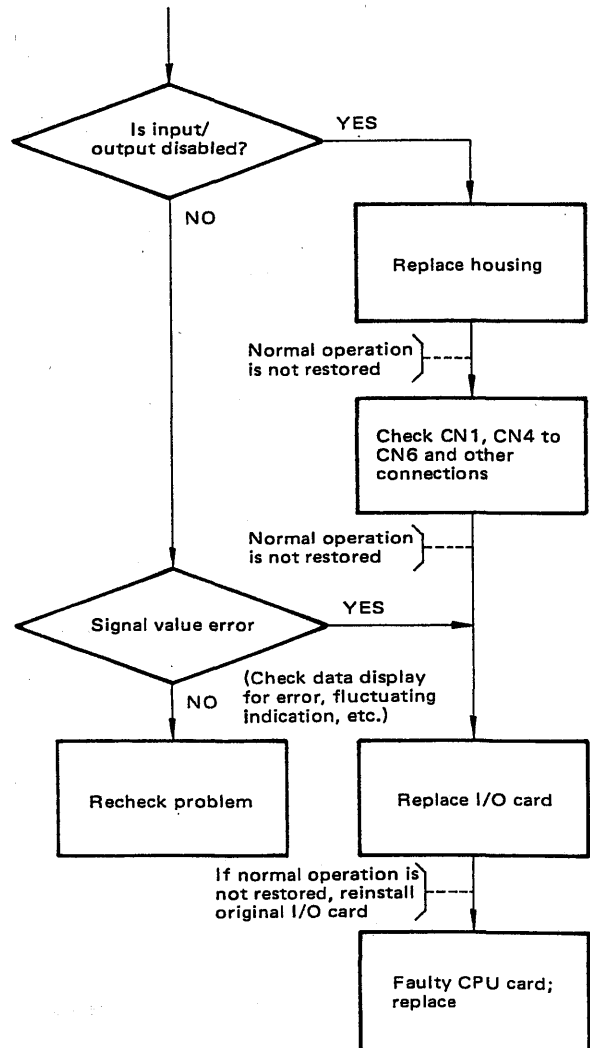

(8) Communications Failure

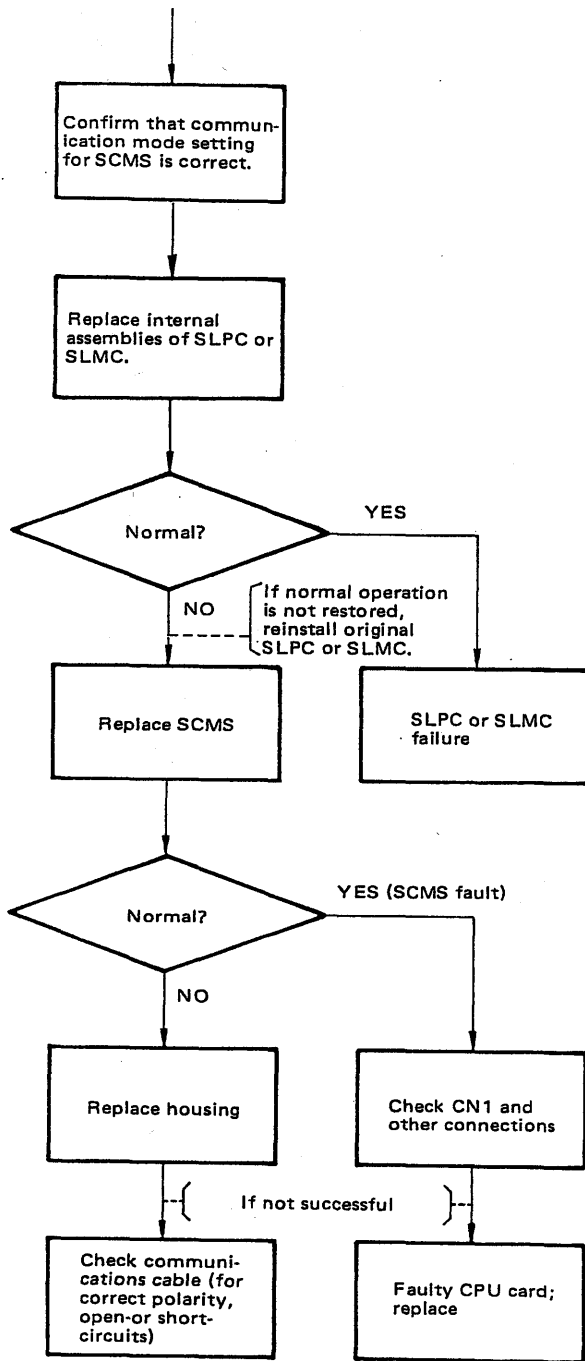

(9) Start Mode Failure

Set MODE 1 to desired status (0: cold start, 1: hot start) and turn power off for the prescribed time interval. Then, if the station fails to start up in the specified mode, the CPU card is faulty. (When an Programmer is connected, even a momentary power interruption is assumed to be a power failure with a duration of 2 seconds or longer.)

## 7-2. Disassembling and Reassembling Procedures.

Follow the disassembly and reassembly procedures in this section to replace possibly faulty units.

### CAUTION

Limit the scope of disassembly to the minimum required. Have the YOKOGAWA service station replace parts not covered in this section.

#### 7-2-1. Removing Cover.

Initially, remove the screw ① to remove the cover as shown in Figure 7-2-1.

#### 7-2-2. Removing Display Assembly.

- (1) Remove seven screws ② in Figure 7-2-2.
- (2) Remove connector CN1.
- (3) Carefully pull the display assembly out toward the front.

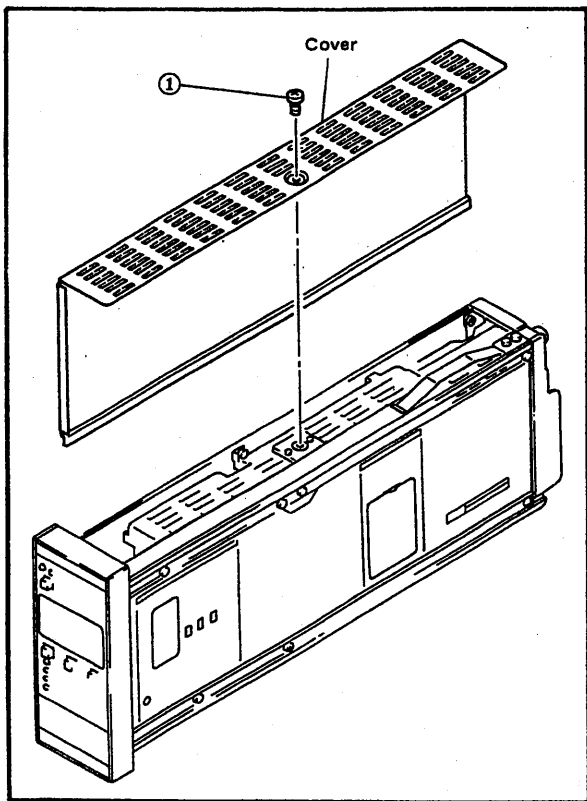

Figure 7-2-1. Removing Cover.

#### 7-2-3. Removing Power Supply Unit.

- (1) Remove four screws ③ in Figure 7-2-2.
- (2) To separate the power supply unit, pull it out toward the rear and remove connector CN2.

#### 7-2-4. Disassembling Control Assembly.

- (1) Remove the display assembly and the power supply unit as instructed in Subsection 7-2-2 and 7-2-3.
- (2) Separate the control assembly from the chassis ⑧ by removing two screws ④ on the right side and at the bottom in Figure 7-2-2.
- (3) Remove two screws ⑤ at the upper and lower part of the left side and open the cover ⑨ to expose two screws ⑥.
- (4) Remove two screws ⑥ to remove the CPU card.
- (5) By disengaging connectors CN3, CN4 and CN5, the I/O card is separated from the CPU card.
- (6) The I/O card can be removed from the bracket ⑩ by removing seven screws ⑦.

#### 7-2-5. Reassembling.

To reassemble with new parts, reverse the disassembly procedures.

##### Assembly notes:

- All screws are of common make.
- Ensure that all necessary connectors have been inserted in proper position.
- In inserting connectors, observe their positions and faces (with bosses, visible) and insides (fits to PC board receptacles).

#### 7-2-6. Checks in Re-supplying Power.

Once the SCMS Computing Station is disassembled, it is initialized with its internal data being lost. The ALM lamp lights when power is re-supplied to the station.

As CHK = 80 is displayed on the front panel, press the data type No. selecting key and enter data into the station again.

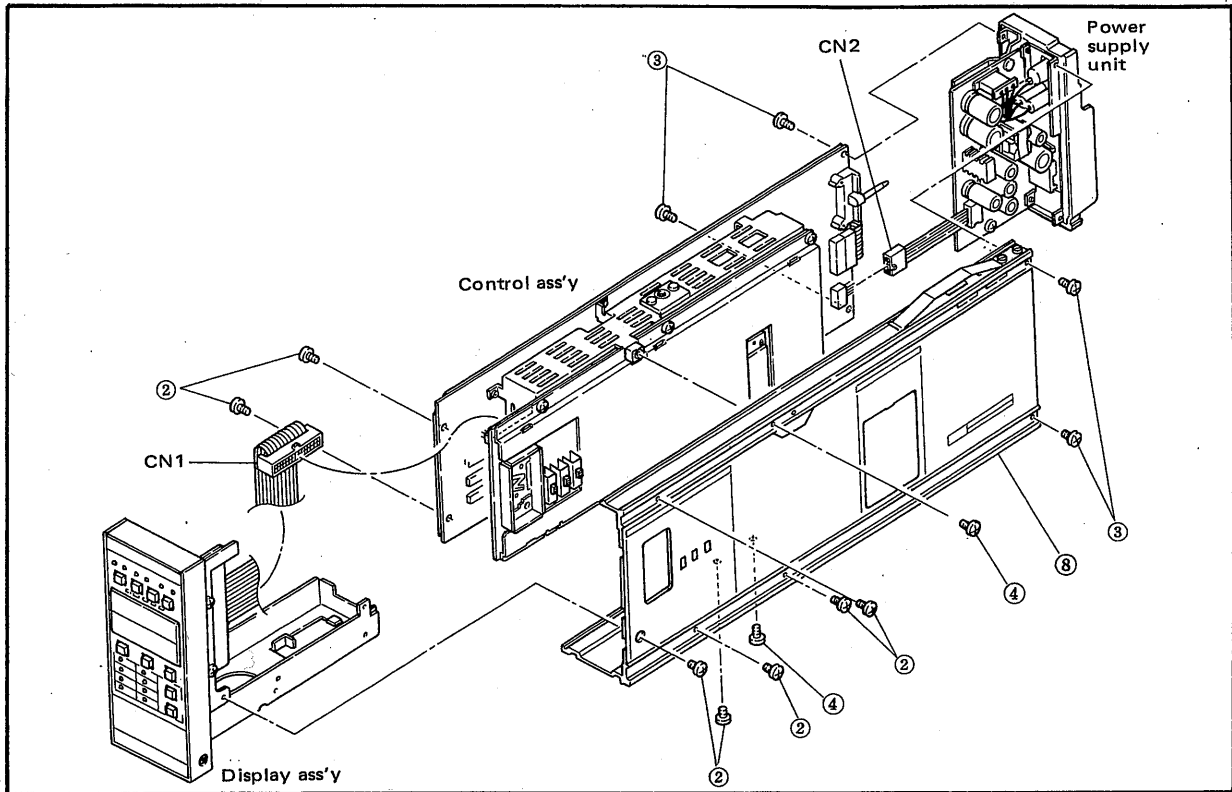

Figure 7-2-2. Removing Display Assembly and Power Supply Unit.

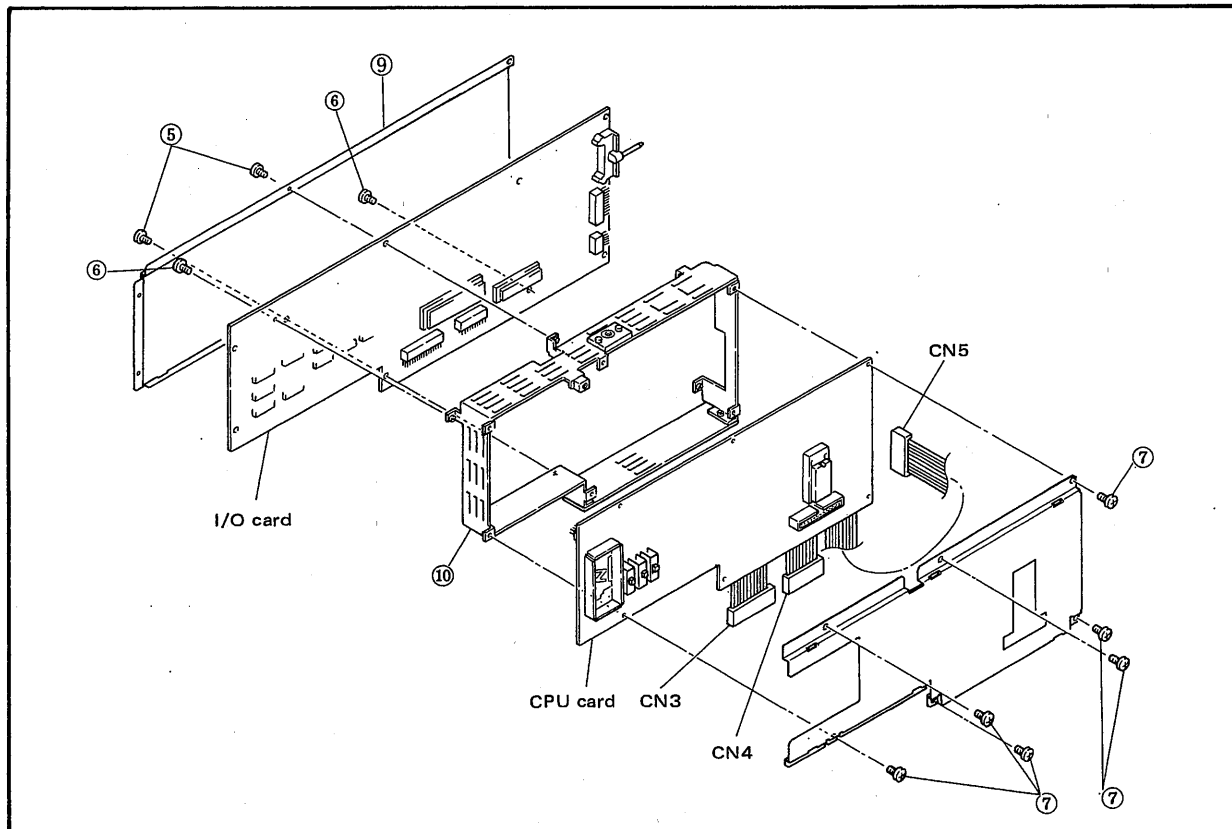

Figure 7-2-3. Disassembling Control Assembly.

Data Label

Use the following label by cutting out it along the broken line if necessary.

SCMS		Computing Station		Tag No.	
X 1			P 1		P 9
X 2			P 2		P10
X 3			P 3		P11
X 4			P 4		P12
Y 1	Y 4		P 5		P13
Y 2	Y 5		P 6		P14
Y 3	Y 6		P 7		P15
Di 1	Do 1		P 8		P16
Di 2	Do 2		T01	E	Lamp&Key
Di 3	Do 3		T	E	Lp 1
Di 4	Do 4		T	E	Lp 2
Di 5	Do 5		T	E	Lp 3
Di 6	Do 6		T	E	Lp 4
Di 7	Do 7		T	E	Ky 1
Di 8	Do 8		T	E	Ky 2
Di 9	Do 9		T	E	Ky 3
Di10	Do10		T	E	Ky 4

SCMS		Computing Station		Tag No.	
X 1			P 1		P 9
X 2			P 2		P10
X 3			P 3		P11
X 4			P 4		P12
Y 1	Y 4		P 5		P13
Y 2	Y 5		P 6		P14
Y 3	Y 6		P 7		P15
Di 1	Do 1		P 8		P16
Di 2	Do 2		T01	E	Lamp&Key
Di 3	Do 3		T	E	Lp 1
Di 4	Do 4		T	E	Lp 2
Di 5	Do 5		T	E	Lp 3
Di 6	Do 6		T	E	Lp 4
Di 7	Do 7		T	E	Ky 1
Di 8	Do 8		T	E	Ky 2
Di 9	Do 9		T	E	Ky 3
Di10	Do10		T	E	Ky 4





# Customer Maintenance Parts List

Model SCMS (Style E)  
Programmable Computing Station

YEW SERIES 80

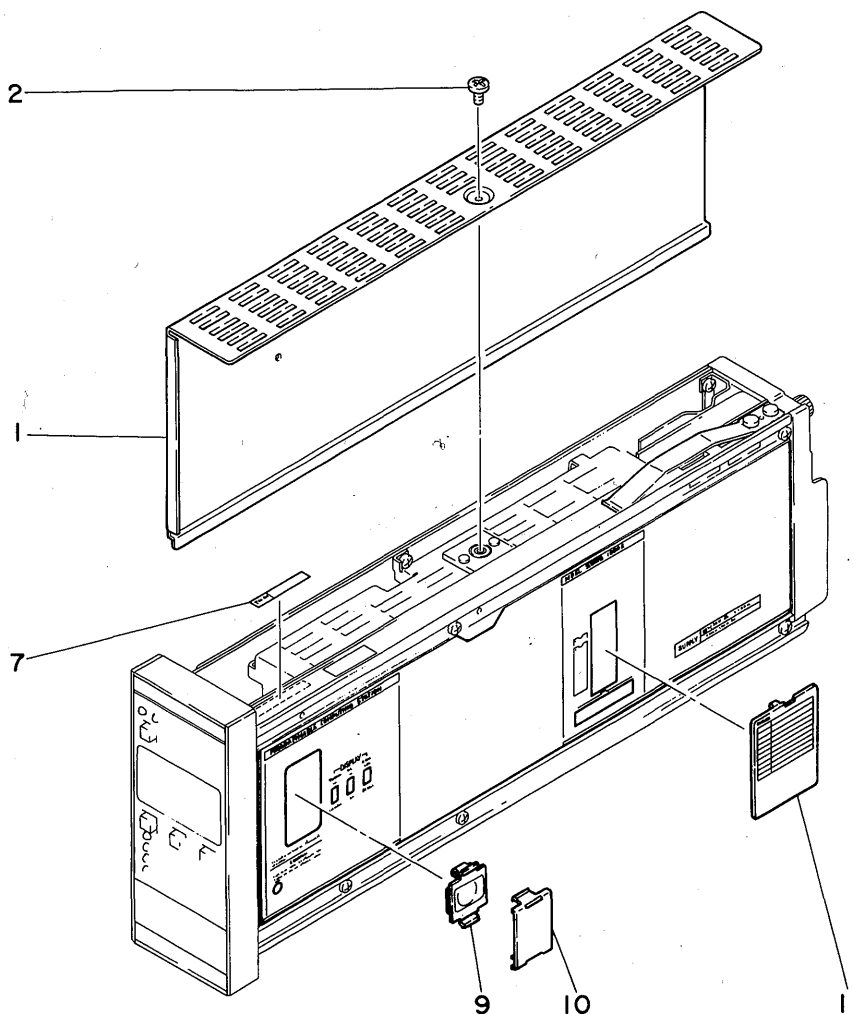

Item	Part No.	Qty	Description
1	E9711TG	1	Cover
2	Y9405LB	1	B.H. Screw, M4 x 5
7	Y9422NP	1	Tag No. Label
9	E9711DH	1	Battery Assembly
10	E9711GQ	1	Cover
11	E9714HQ	1	Cover

2

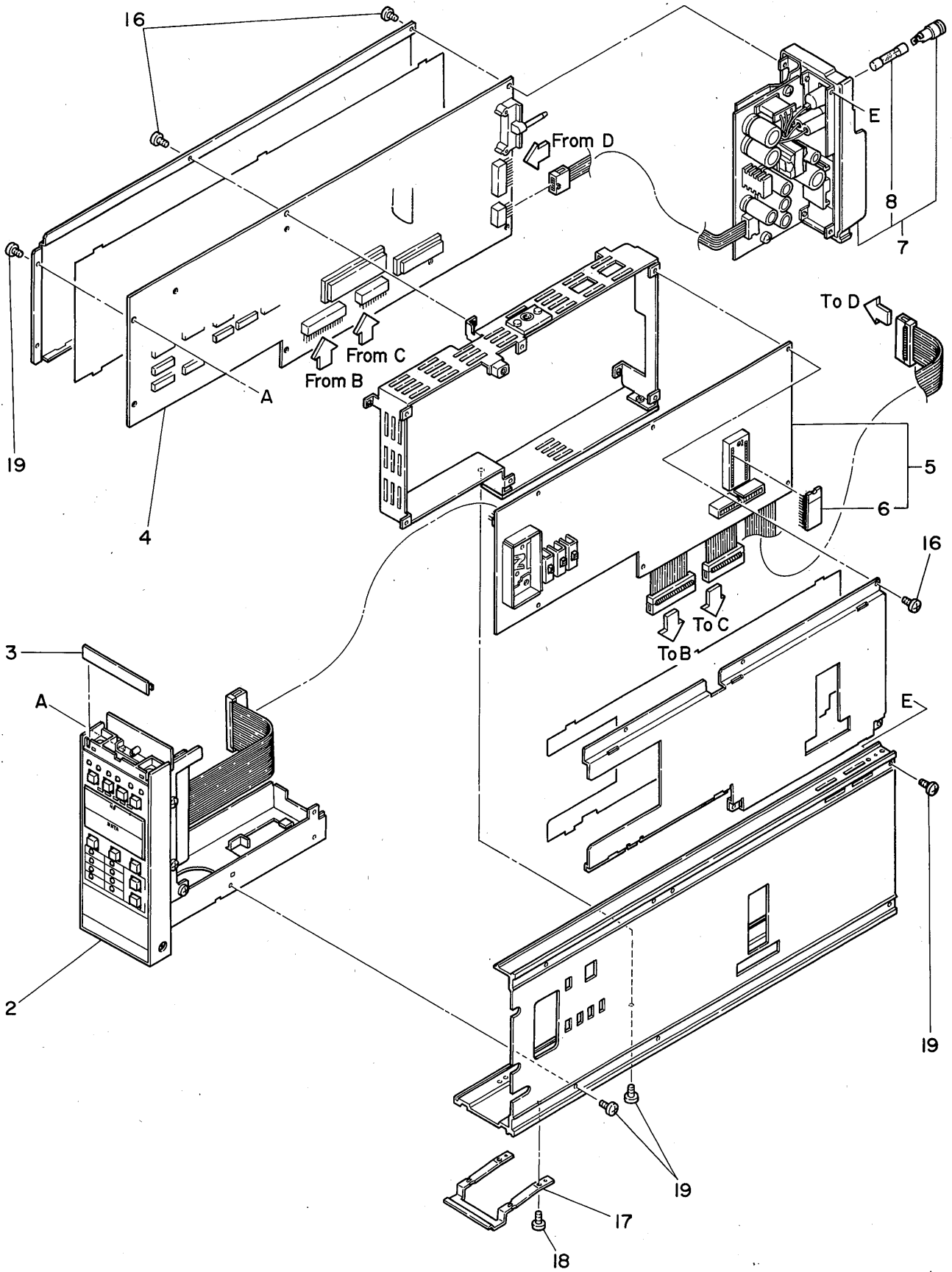

Item	Part No.	Qty	Description
2	—	1	Display Assembly (see page 4)
3	E9711FG	1	Plate (blank)
—	—	1	Control Assembly (items 4 through 16)
4	E9714LJ	1	I/O Card
5	E9714MJ	1	CPU Card
6	G9003LT	1	EP ROM
7	Below	1	Power Supply Unit
	E9716YB		For 100 V Version
	E9716YS		For 220 V Version
8	S9510VK	1	Fuse — "1A"
16	Y9306JB	12	Pan H. Screw, M3 x 6
17	E9711TD	1	Stopper
18	E9711TE	2	Screw
19	Y9306JB	10	Pan H. Screw, M3 x 6

### Display Assembly

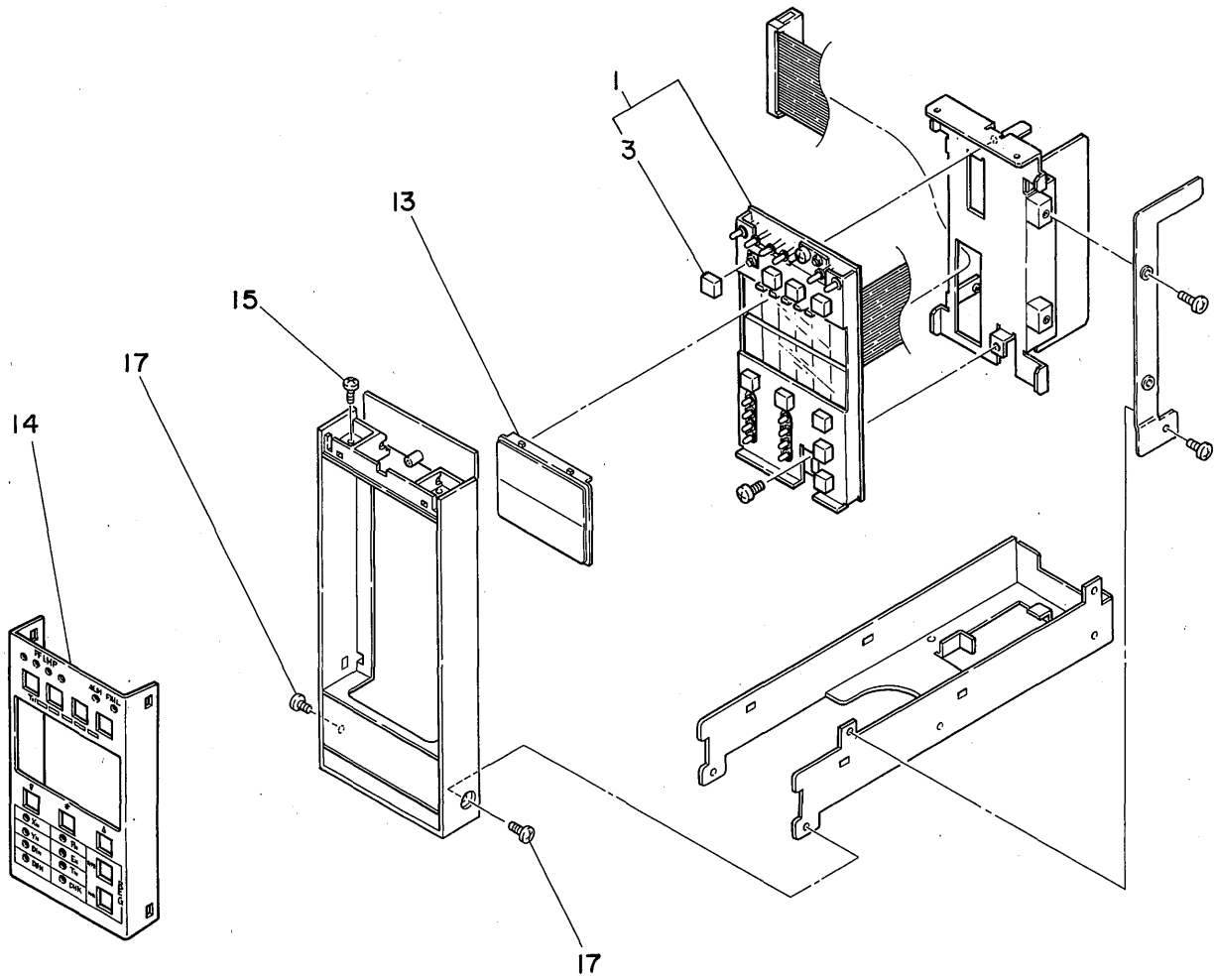

Item	Part No.	Qty	Description
—	E9714GA	1	Display Assembly (items 2 through 15)
1	E9714PA	1	Display Card Assembly
3	E9712CC	8	Key Top
13	E9714GH	1	Cover
14	E9714GJ	1	Bracket
15	Y9306JB	2	Pan H. Screw, M3 x 6
17	Y9306JB	2	Pan H. Screw, M3 x 6

# Instruction Manual

## / HTB Power Supply Terminal Connections for Panel - mounted Instruments (Option)

### 1. GENERAL.

If you specify the terminal board to which the power source is directly connected (suffix code / HTB), the external wiring to the terminal board is necessary.

### 2. APPLICABLE INSTRUMENTS.

Model	Description
SRVD	Strip Chart Recorder
SIHM	Indicator (With Housing)
SIHF	Bar Graph Indicator (With Alarms)
SIHK	Indicator (With Alarms)
SLCD	Indicating Controller
SLPC	Programmable Indicating Controller
SLMC	Programmable Indicating Controller with Pulse → Width Output
SMLD	Manual Station
SMST	Auto / Manual Station
SMRT	Ratio Set Station
SCMS	Programmable Computing Station
SBSD	Batch Set Station
SLCC	Blending Controller
SLBC	Batch Controller
STLD	Totalizer

### 3. NAME OF COMPONENTS AND TERMINAL DESIGNATION OF POWER SUPPLY

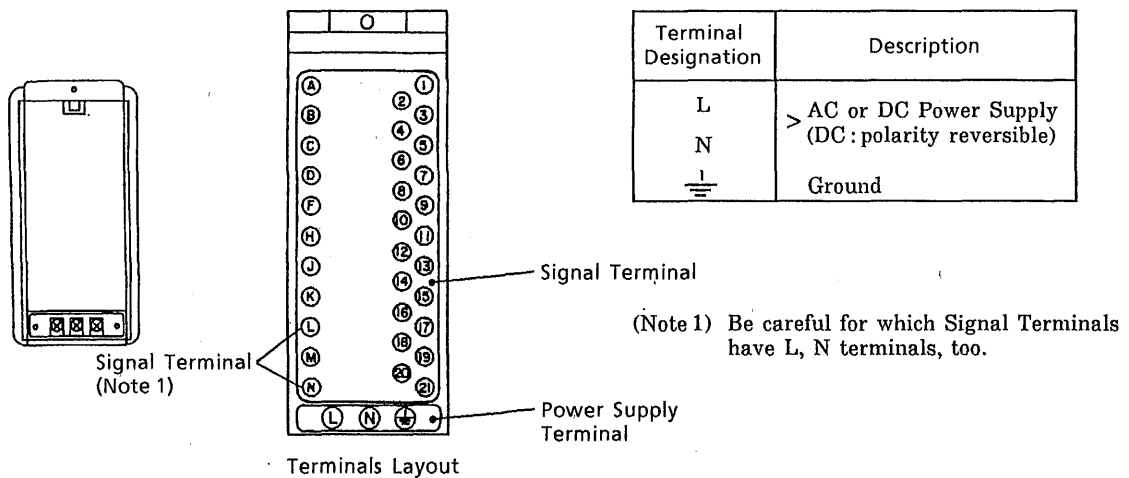

### 4. POWER SUPPLY AND GROUND WIRING.

(1) All cable ends must be furnished with crimp - on type solderless lugs (for 4mm screw).

(2) Examples of applicable cables.

Cross - sectional area of the cable conductor : 2.0mm<sup>2</sup>.\*

Note \* : Power supply cables should be determined from the instrument power consumption  
- they must have conductors with cross - sectional area of at least 1.25mm<sup>2</sup>.

Applicable cable : 600V vinyl insulated cable (IV), conforming to JIS C3307.

Vinyl sheathed cables for electric appliances (KIV), conforming to JIS C3316.

(3) After completing the power supply and ground wiring, mount the power terminal cover.